

# Integra SERVICE MANUAL

Sep, 2001
-----------

## DVD AUDIO/VIDEO PLAYER MODEL DPS-7.2

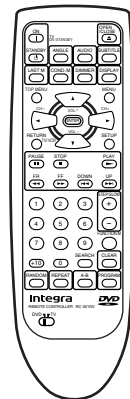
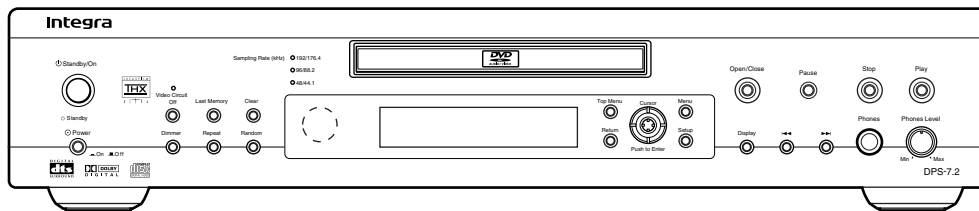

RC-451DV

### Black model

BMDD1N	120V AC, 60Hz
--------	---------------

### SAFETY-RELATED COMPONENT WARNING!!

COMPONENTS IDENTIFIED BY MARK  ON THE SCHEMATIC DIAGRAM AND IN THE PARTS LIST ARE CRITICAL FOR RISK OF FIRE AND ELECTRIC SHOCK. REPLACE THESE COMPONENTS WITH ONKYO PARTS WHOSE PART NUMBERS APPEAR AS SHOWN IN THIS MANUAL.

MAKE LEAKAGE-CURRENT OR RESISTANCE MEASUREMENTS TO DETERMINE THAT EXPOSED PARTS ARE ACCEPTABLY INSULATED FROM THE SUPPLY CIRCUIT BEFORE RETURNING THE APPLIANCE TO THE CUSTOMER.

## SPECIFICATIONS

### ■ DVD Player

<b>Power supply</b>	AC 120 V, 60 Hz
<b>Power consumption</b>	16 W
<b>Weight</b>	3.6 kg, 7.9 lbs.
<b>External dimensions</b>	435 × 91 × 314 mm (W/H/D), 17-1/8" × 3-9/16" × 12-3/8"
<b>Signal system</b>	Standard NTSC
<b>Regional restriction code</b>	1
<b>Laser</b>	Semiconductor laser, wavelength 650 nm
<b>Frequency range (digital audio)</b>	DVD linear sound: 48 kHz sampling 4 Hz to 22 kHz 96 kHz sampling 4 Hz to 44 kHz DVD-Audio: 192 kHz sampling 4 Hz to 96 kHz Audio CD: 4 Hz to 20 kHz
<b>Signal-to-noise ratio (digital audio)</b>	More than 106 dB
<b>Audio dynamic range (digital audio)</b>	More than 100 dB
<b>Harmonic distortion (digital audio)</b>	Less than 0.005 %
<b>Wow and flutter</b>	Below measurable level (less than ±0.001 % (W.PEAK))
<b>Operating conditions</b>	Temperature: 5°C to 35°C, Operation status: Horizontal

### ■ Outputs

<b>Video output</b>	1.0 V (p-p), 75 Ω, negative sync., pin jack × 2
<b>S-video output</b>	(Y) 1.0 V (p-p), 75 Ω, negative sync., Mini DIN 4-pin × 2 (C) 0.286 V (p-p), 75 Ω
<b>Component video output</b>	(Y) 1.0 V (p-p), 75 Ω, negative sync., pin jack × 2 (P <sup>B</sup> )/(P <sup>R</sup> ) 0.7 V (p-p), 75 Ω
<b>Audio output (digital output Optical)</b>	Optical connector × 2
<b>Audio output (digital output Coaxial)</b>	0.5 V (p-p), 75 Ω, pin jack × 1
<b>Audio output (analog audio)</b>	2.0 V (rms), 470 Ω, pin jack (L, R) × 2
<b>Audio output (5.1 channel analog audio)</b>	2.0 V (rms), 470 Ω, pin jack (FRONT L, FRONT R, CENTER, SURR L, SURR R, SUB WOOFER) × 1

Specifications and features are subject to change without notice.

# SERVICE PROCEDURES-1

## PROTECTION OF EYES FROM LASER BEAM DURING SERVICING

This set employs a laser. Therefore, be sure to follow carefully the instructions below when servicing.

**WARNING!!**

**SERVICE WARNING : DO NOT APPROACH THE LASER EXIT WITH THE EYE TOO CLOSELY. IN CASE IT IS NECESSARY TO CONFIRM LASER BEAM EMISSION, BE SURE TO OBSERVE FROM A DISTANCE OF MORE THAN 30cm FROM THE SURFACE OF THE OBJECTIVE LENS ON THE OPTICAL PICKUP BLOCK.**

### Laser Diode Properties

CD  
 Wavelength: 650 nm  
 Laser output: 0.43 mW

DVD  
 Wavelength: 780 nm  
 Laser output: 0.14 mW

## WARNING

**WARNING:**

TO REDUCE THE RISK OF FIRE OR ELECTRIC SHOCK, DO NOT EXPOSE THIS APPLIANCE TO RAIN OR MOISTURE.

**CAUTION:**

TO REDUCE THE RISK OF ELECTRIC SHOCK, DO NOT REMOVE COVER (OR BACK). NO USER-SERVICEABLE PARTS INSIDE. REFER SERVICING TO QUALIFIED SERVICE PERSONNEL.



**WARNING**  
 RISK OF ELECTRIC SHOCK  
 DO NOT OPEN

**AVIS**  
 RISQUE DE CHOC ELECTRIQUE  
 NE PAS OUVRIR



The lightning flash with arrowhead symbol, within an equilateral triangle, is intended to alert the user to the presence of uninsulated "dangerous voltage" within the product's enclosure that may be of sufficient magnitude to constitute a risk of electric shock to persons.



The exclamation point within an equilateral triangle is intended to alert the user to the presence of important operating and maintenance (servicing) instructions in the literature accompanying the appliance.

## LASER WARNING

This unit contains a semiconductor laser system and is classified as a "CLASS 1 LASER PRODUCT". So, to use this model properly, read this Instruction Manual carefully. In case of any trouble, please contact the store where you purchased the unit. To prevent being exposed to the laser beam, do not try to open the enclosure.

**CAUTION:**

VISIBLE LASER RADIATION WHEN OPEN AND INTERLOCK FAILED OR DEFEATED. DO NOT STARE INTO BEAM.

**CAUTION:**

THIS PRODUCT UTILIZES A LASER. USE OF CONTROLS OR ADJUSTMENTS OR PERFORMANCE OF PROCEDURES OTHER THAN THOSE SPECIFIED HEREIN MAY RESULT IN HAZARDOUS RADIATION EXPOSURE.

The label on the right is applied on the rear panel except for USA and Canadian models.



1. This unit is a CLASS 1 LASER PRODUCT and employs a laser inside the cabinet.
2. To prevent the laser from being exposed, do not remove the cover. Refer servicing to qualified personnel.

## SERVICE PROCEDURE

### 1. Replacing the fuses

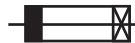

This symbol located near the fuse indicates that the fuse used is show operating type, For continued protection against fire hazard, replace with same type fuse , For fuse rating, refer to the marking adjust to the symbol.

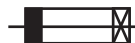

Ce symbole indique que le fusible utilise est e lent. Pour une protection permanente, n'utiliser que des fusibles de meme type. Ce demier est indique la qu le present symbol est apposse.

REF. NO.	PART NO.	DESCRIPTION
F1	252147 or	1.6A-TSC or
	252252	1.6A-T/UL-ST2

### 2. Safety-check out

After correcting the original service problem perform the following safety check before releasing the set to the customer Connect the insulating-resistance tester between the plug of power supply cord and terminal GND on the back panel. Specifications: More than 10M ohm at 500V

### LASER BEAM CAUTION LABEL



WAVE LENGTH:650nm  
 MAX.LASER POWER:0.5mW  
 波 長 : 650nm  
 最大レーザー出力 : 0.5mW

98764160



# EXPLODED VIEW

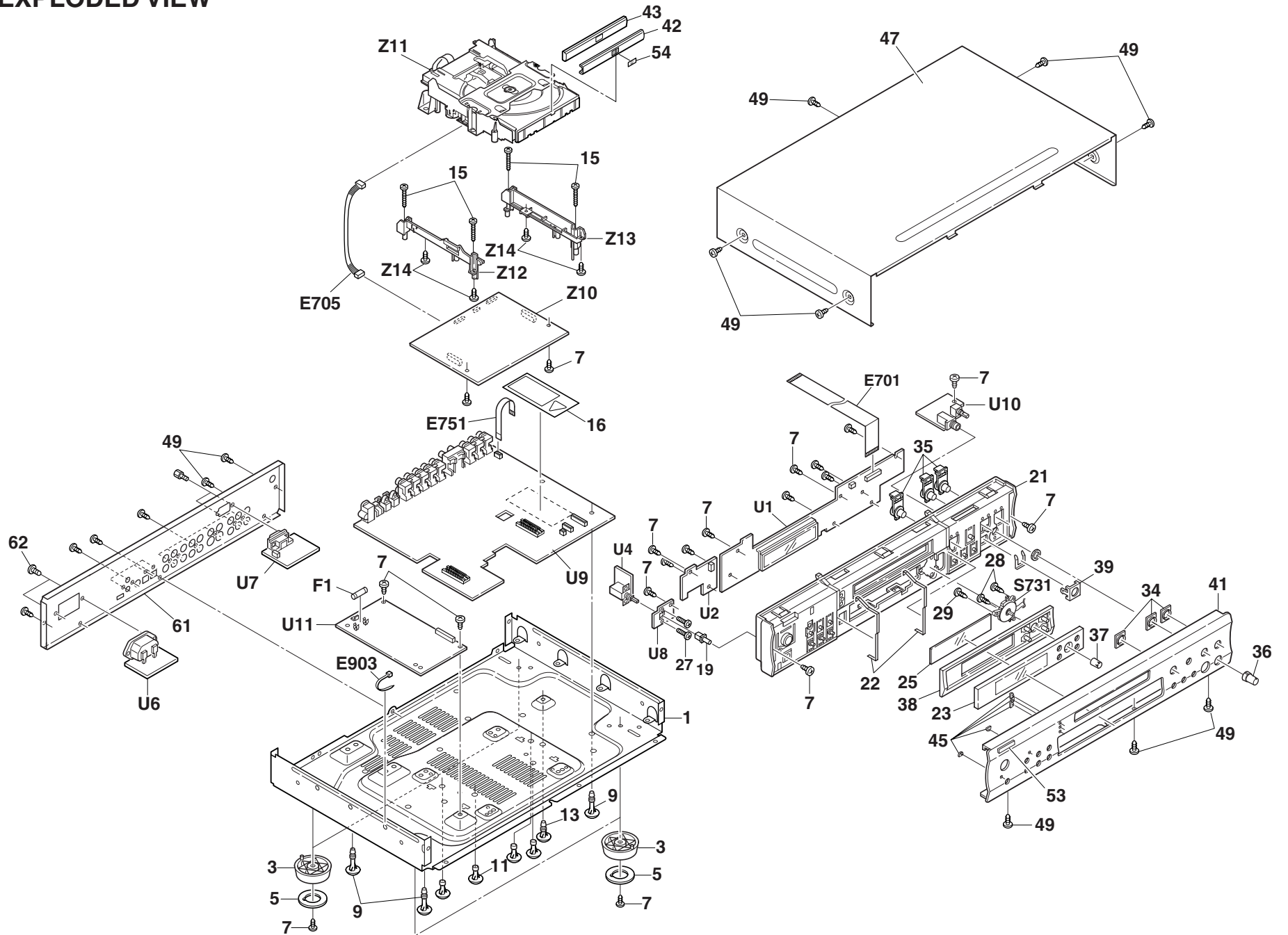

## EXPLODED VIEW PARTS LIST

REF.NO.	PART NO.	DESCRIPTION	REF.NO.	PART NO.	DESCRIPTION
1	27100399A	Chassis	47	28184808	Top cover
3	27175316B	Leg	49	838430088	3TTB+8B(BC), Self tapping screw
5	28141332	Cushion	53	28135278	Badge
7	838130088	3TTB+8B, Self tapping screw	54	28135284	Badge, DVD-AUDIO
9	27190428A	KGLS-10RF, Holder	62	838440089	4TTC+8C(BC), Self tapping screw
11	27191112	KGPS-6RF, Holder	61	27122903B	Rear panel
13	27190693	KGLS-6R, Holder	E701	2045222012	NCFC5-222012, Flexible flat cable
15	838130208	3TTB+20B, Self tapping screw	E705	200990702UL	NSAS-10P0978
16	29362584	⚠ Label DVD	E751	2045081212	NCFC5-081212, Flexible flat cable
19	28325753	Knob power	E903	260208	Binder, UL
21	27111221A	Front bracket	F1	252147 or	⚠ 1.6A-TSC or
21	28325756	Knob, STANDBY		252252	⚠ 1.6A-T/UL-ST2
23	28191928	Clear plate	S731	25035710	NPS-115-S673, Cursor switch ass'y
25	28133398	B plate	Z10	24150022	DB-VPB302, Main PC board ass'y
27	82143010	3P+10FN(BC), Pan head screw	Z11	24801010	DB-VLD301-006, DVD mechanism ass'y
28	838126068	2.6TTB+6B, Self tapping screw	Z12	24840149A	DB-VAC301, adapter(L)
29	838426088	2.6TTB+8B(BC), Self tapping screw	Z13	24840150A	DB-VAC302, adapter(R)
31	28198935	Facet, PLAY	U1	1H465515-1G	NADIS-7215-1G, Display PC board ass'y
34	27268054	Guide, knob	U2	1H465516-1G	NADIS-7216-1G, Control switch PC board ass'y
35	28325958	Knob G, OPEN AS	U4	1H465518-1G	NASW-7218-1G, Power switch PC board ass'y
36	28325452	Knob, MIC	U6	1H465520-1G	NAPS-7220-1G, AC inlet PC board ass'y
37	28325933	Knob, CRS	U7	1H465515-1G	NAETC-7221-1G, RS-232C connector PC board ass'y
38	27191142A	Holder, PLT	U8	1H465515-1B	NAETC-7222-1B, Holder PC board ass'y
39	27191155	Holder, HP	U9	1H465524-1D	NAAR-7224-1D, Output terminal PC board ass'y
41	27212327A	Front panel	U10	1H465525-1D	NAETC-7225-1D, Phones jack PC board ass'y
42	28148488	Door	U11	24150020A	⚠ NGPS-0020-120V, Power supply unit
43	28148491	Door, MOULD			
45	28198906	Facet, S			

**NOTE:** THE COMPONENTS IDENTIFIED BY MARK ⚠ ARE CRITICAL FOR RISK OF FIRE AND ELECTRIC SHOCK. REPLACE ONLY WITH PART NUMBER SPECIFIED.

# EXPLODED VIEWS OF MECHANISM

## DVD MECHANISM : DB-VLD301-006

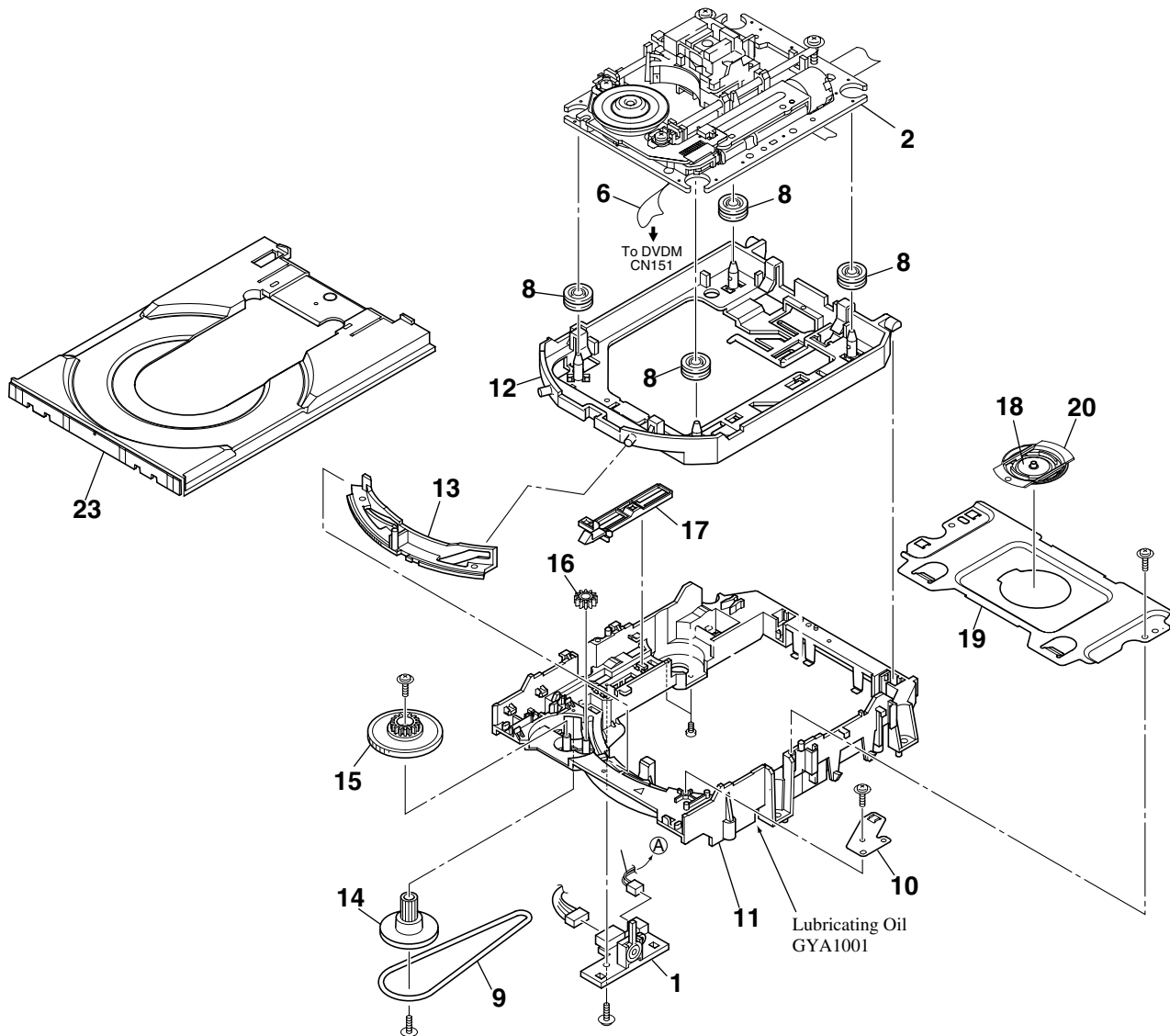

### PARTS LIST

REF.NO	PART NO.	DESCRIPTION	REF.NO.	PART NO.	DESCRIPTION
1	VNP1836	Loading PC board assy	12	VNL1918	Float base DVD
2	VXX2782	Traverse mechanism assy	13	VNL1919	Drive cam
6	VDA1864	Flexible cable 26P	14	VNL1921	Gear pulley
8	VEB1327	Float rubber	15	VNL1922	Loading gear
9	VEB1328	Belt	16	VNL1923	Drive gear
10	VNE2253	Stabilizer	17	VNL1925	SW lever
11	VNL1917	Loading base	18	VNE2251	Clamper plate
			19	VNE2252	Bridge
			20	VNL1924	Clamper
			23	VNL1920	Tray

A

B

C

D

BLOCK DIAGRAMS-1

OVERALL

1

2

3

4

5

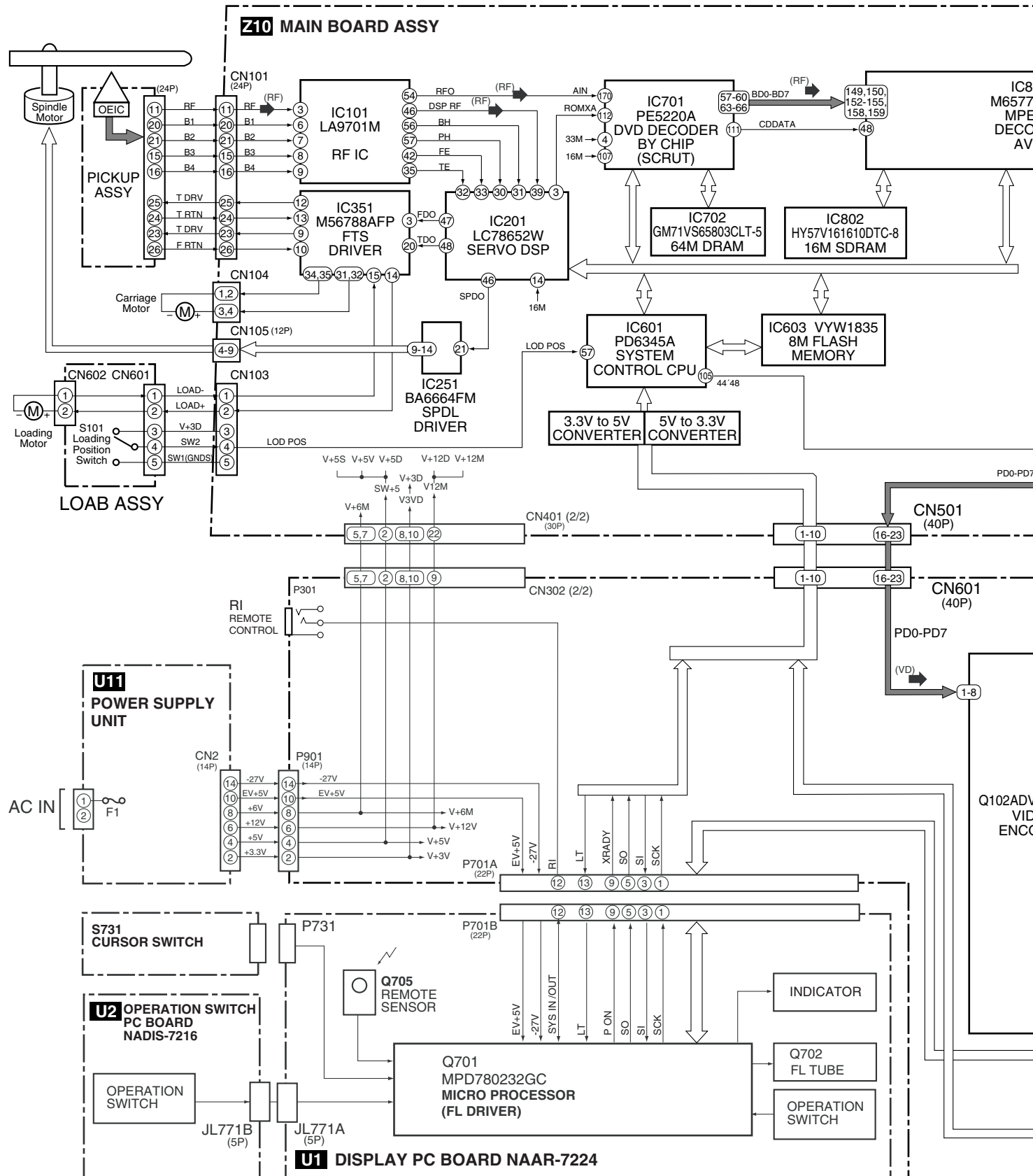

Q102ADV  
VID  
ENCC

A

B

C

D

**BLOCK DIAGRAMS-2**  
**MECHANISM SECTION**

- (RF) : RF SIGNAL ROUTE
- (F) : FOCUS SERVO LOOP LINE
- (T) : TRACKING SERVO LOOP LINE
- (S) : SLIDER SERVO LOOP LINE

1

**PICKUP ASSY**

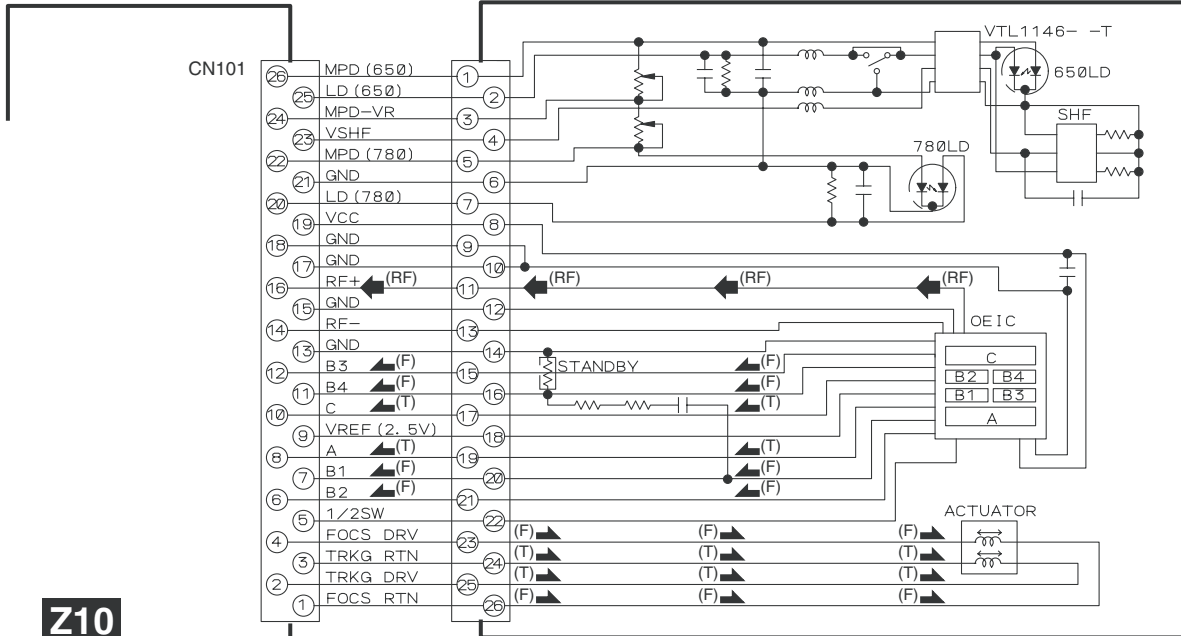

2

**Z10**  
**MAIN BOARD**

3

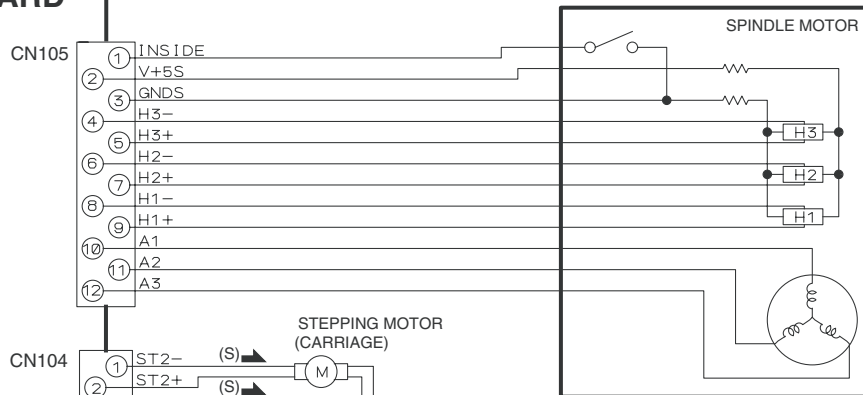

4

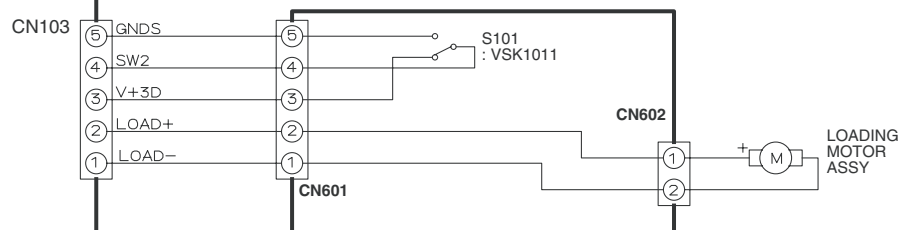

5

**LOAD ASSY**



E

F

G

H

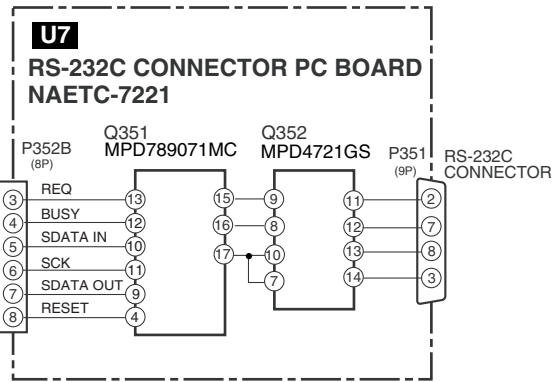
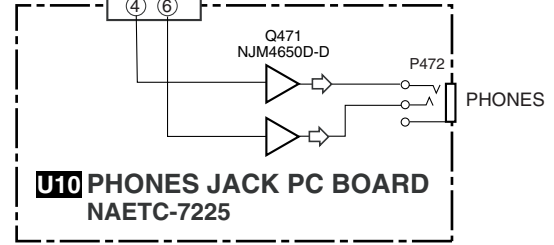
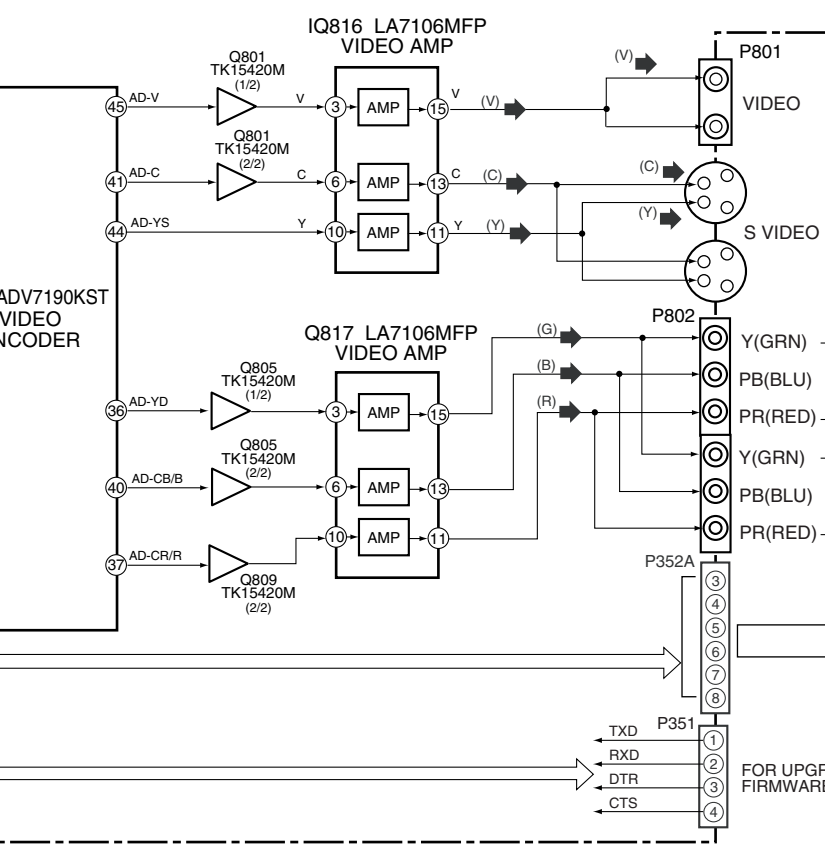
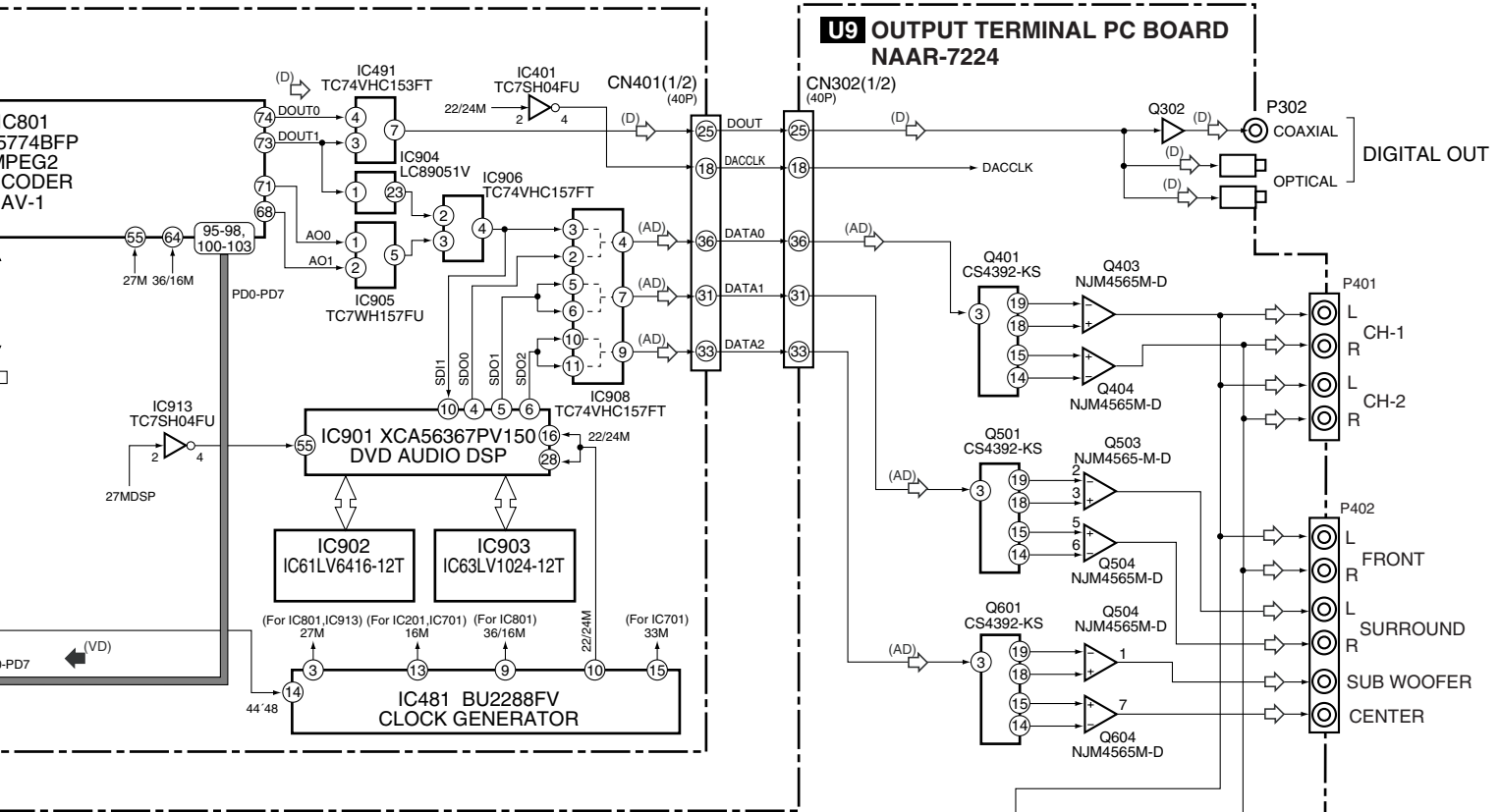
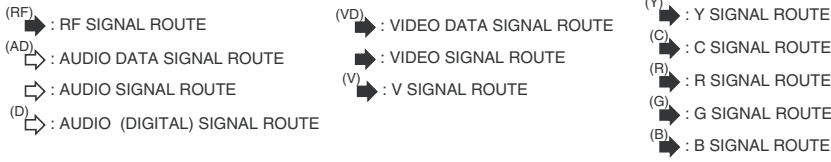





**U2 OPERATION SWITCH PC BOARD**

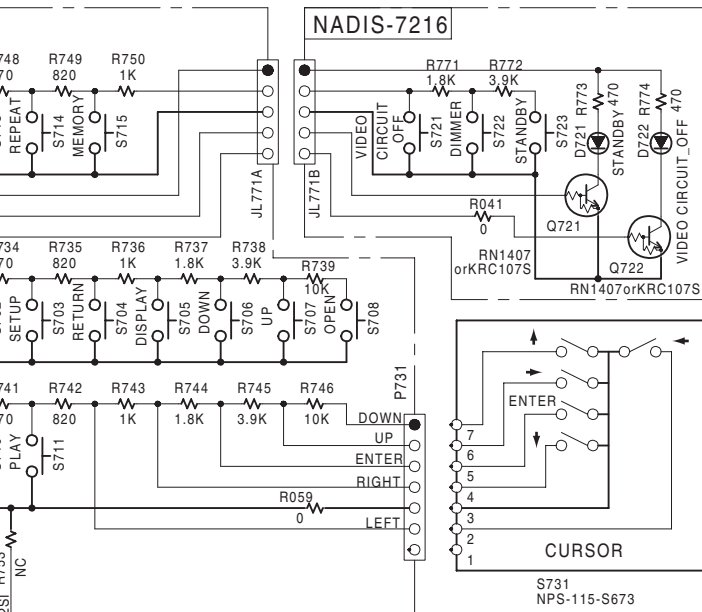

**U11 POWER SUPPLY UNIT**

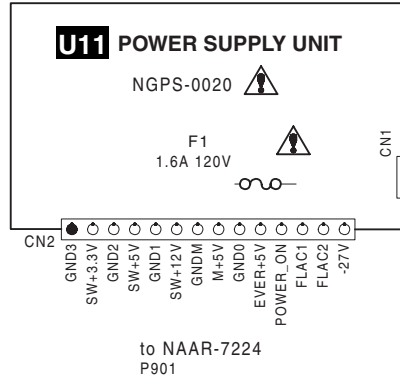

**U6 AC INLET PC BOARD**

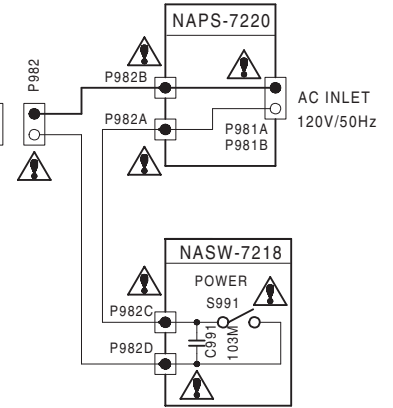

**U4 POWER SWITCH PC BOARD**

**U7 RS-232C CONNECTOR PC BOARD**

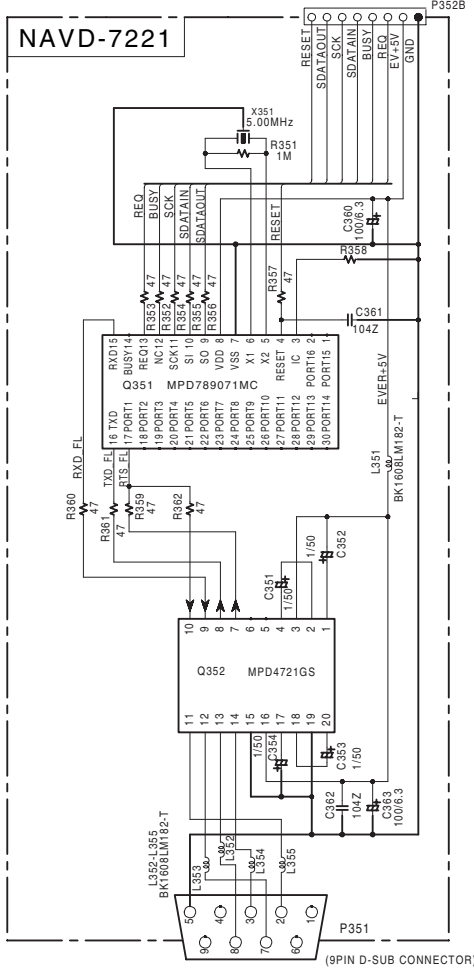

RS-232C CONNECTOR

THIS SYMBOL LOCATED NEAR THE FUSE INDICATES THAT THE FUSE USED IS SLOW OPERATING TYPE FOR CONTINUED PROTECTION AGAINST FIRE HAZARD, REPLACE WITH SAME TYPE FUSE. FOR FUSE RATING REFER TO THE MARKING ADJACENT TO THE SYMBOL

CE SYMBOLE INDIQUE QUE LE FUSIBLE UTILISE EST LENT. POUR UNE PROTECTION PERMANENTE, N'UTILISER QUE DES FUSIBLES DE MEME TYPE. CE DERNIER EST INDIQUE LA QU LE PRESENT SYMBOLE EST APPOSE.

**CAUTION**  
FOR CONTINUED PROTECTION AGAINST FIRE HAZARD, REPLACE ONLY WITH FUSE OF SAME TYPE AND RATING INDICATED.

**ATTENTION**  
AFIN D'ASSURER UNE PROTECTION PERMANENTE CONTRE LES RISQUES D'INCENDIE, REMPLACER UNIQUEMENT PAR UN FUSIBLE DE MEME TYPE ET CALIBRATION COMME INDIQUE.

ARE CRITICAL FOR SAFETY.  
IFIED.  
IS DCVOLTAGE. (NO INPUT SIGNAL)  
N UP/WV.  
S OTHERWISE NOTED.  
.033uF  
UNLESS OTHERWISE NOTED.  
PRINTING SIDE OF THE PARTS.  
ROVEMENT.

A

B

C

D

SCHEMATIC DIAGRAMS-2

NC : No connecton

1

2

3

4

5

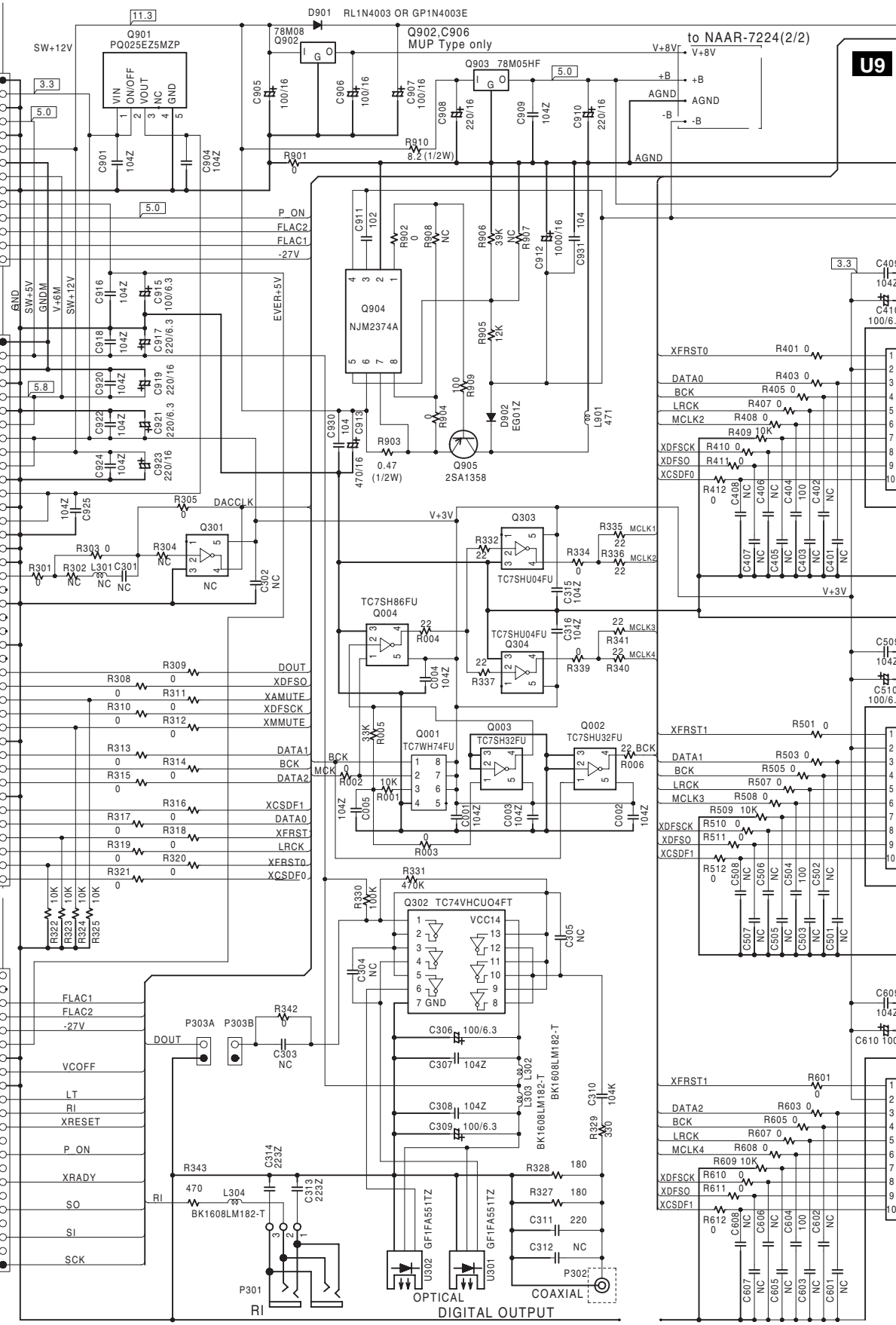
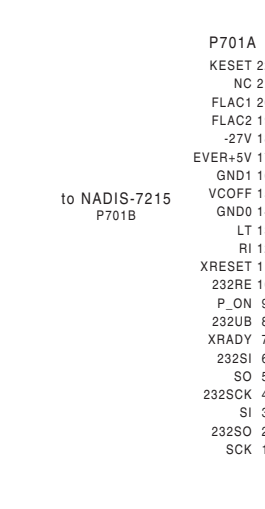
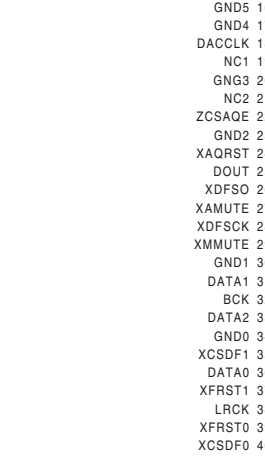
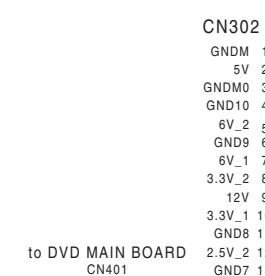
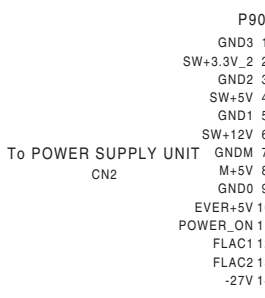

U9 O P

NAAR-7224 (1/2)

OUTPUT TERMINAL PC BOARD

Q401 CS4392

1 RST	AMUTE	20
2 VL	AOUTA-	19
3 SDATA	AOUTA+	18
4 SCLK	VA	17
5 LRCK	AGND	16
6 MCLK	AOUTB+	15
7 M3	AOUTB-	14
8 M2	BMUTE	13
9 M1	CMOUT	12
10 M0	FILT+	11

Q501 CS4392

1 RST	AMUTE	20
2 VL	AOUTA-	19
3 SDATA	AOUTA+	18
4 SCLK	VA	17
5 LRCK	AGND	16
6 MCLK	AOUTB+	15
7 M3	AOUTB-	14
8 M2	BMUTE	13
9 M1	CMOUT	12
10 M0	FILT+	11

Q601 CS4392

1 RST	AMUTE	20
2 VL	AOUTA-	19
3 SDATA	AOUTA+	18
4 SCLK	VA	17
5 LRCK	AGND	16
6 MCLK	AOUTB+	15
7 M3	AOUTB-	14
8 M2	BMUTE	13
9 M1	CMOUT	12
10 M0	FILT+	11

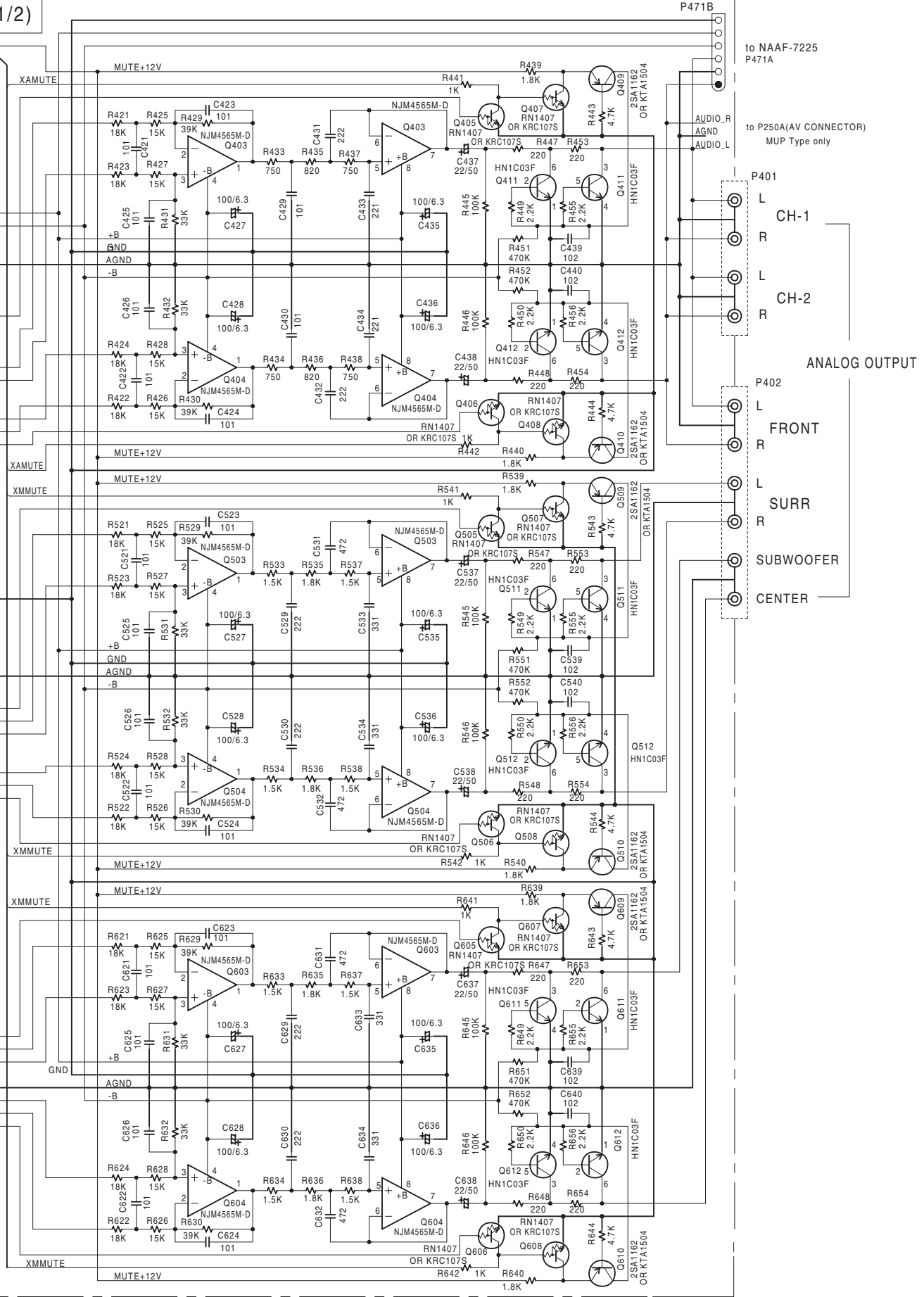

to NAAF-7225 P471A

to P250A(AV CONNECTOR) MUP Type only

P401

L CH-1

R CH-1

L CH-2

R CH-2

ANALOG OUTPUT

P402

L FRONT

R FRONT

L SURR

R SURR

L SUBWOOFER

R SUBWOOFER



A B C D  
SCHEMATIC DIAGRAMS-3

1

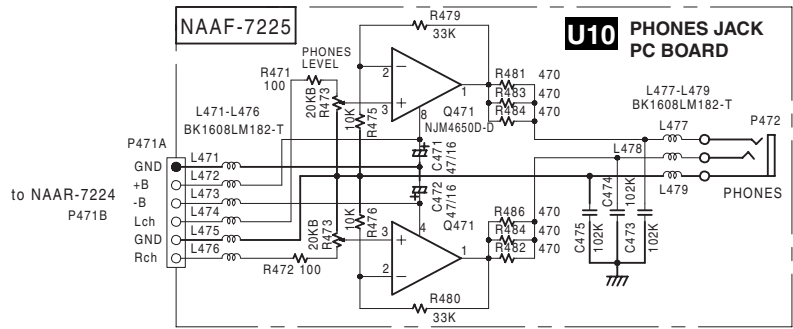

NAAR-7224(2/2)

U9 OUTPUT TERMINAL PC BOARD

2

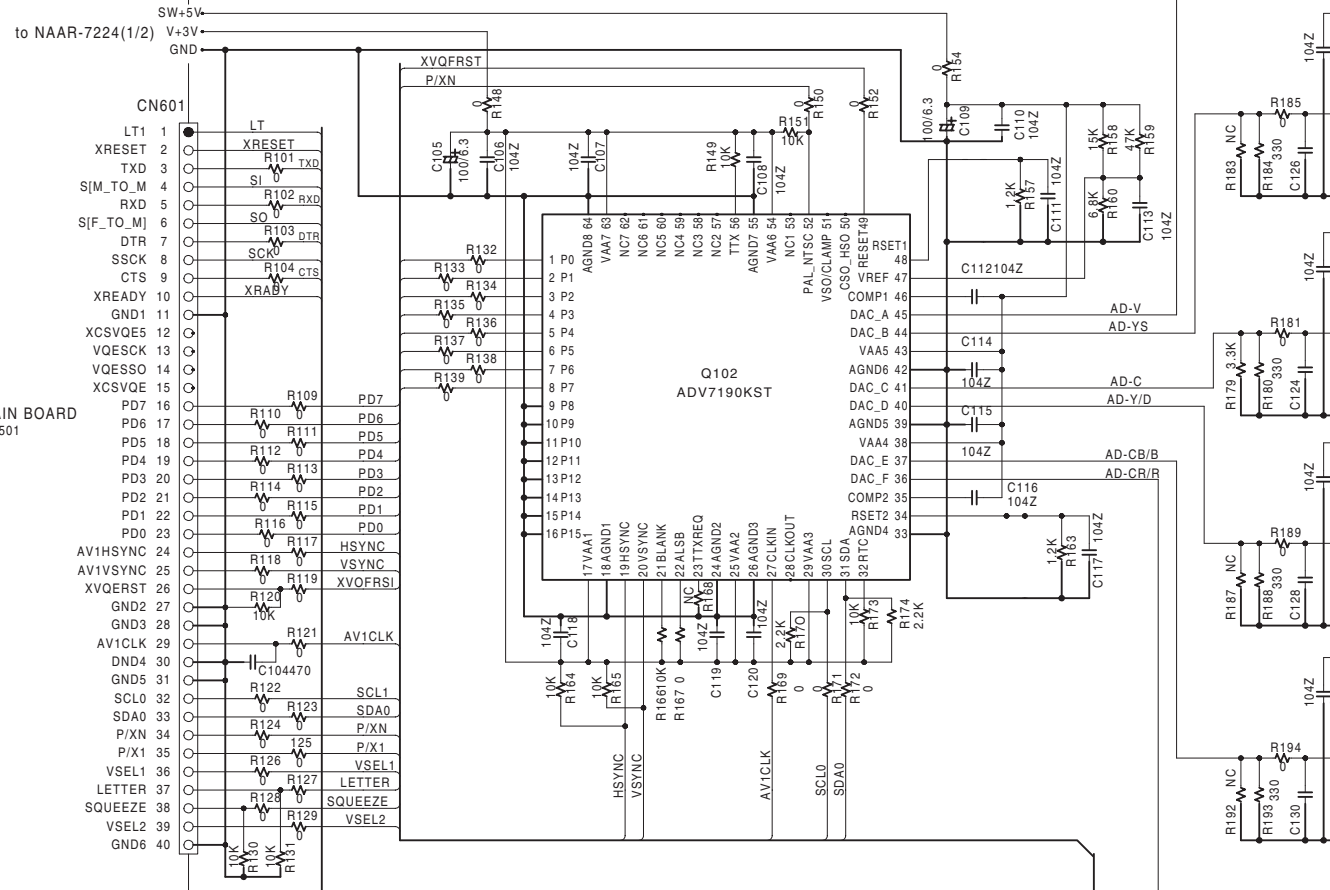

3

4

5

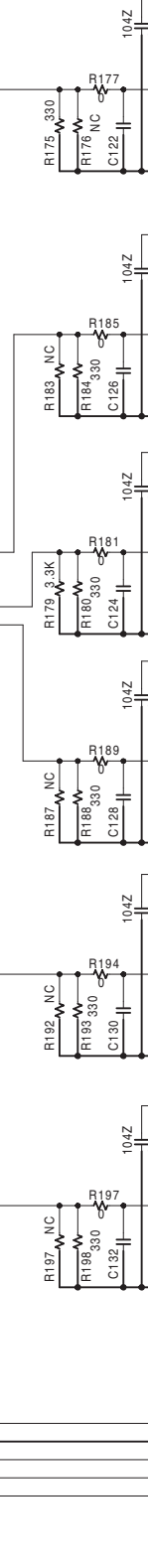
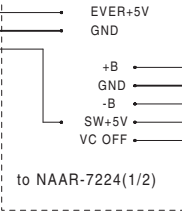
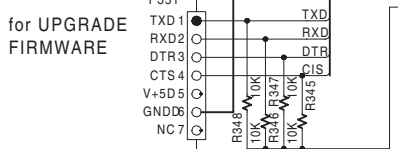
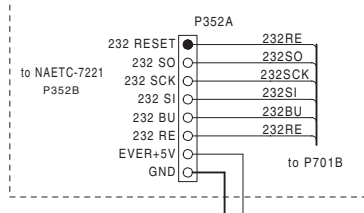
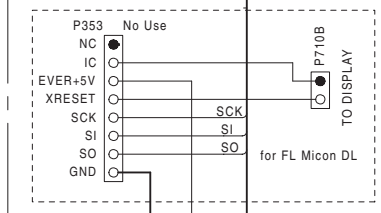

E

F

G

H

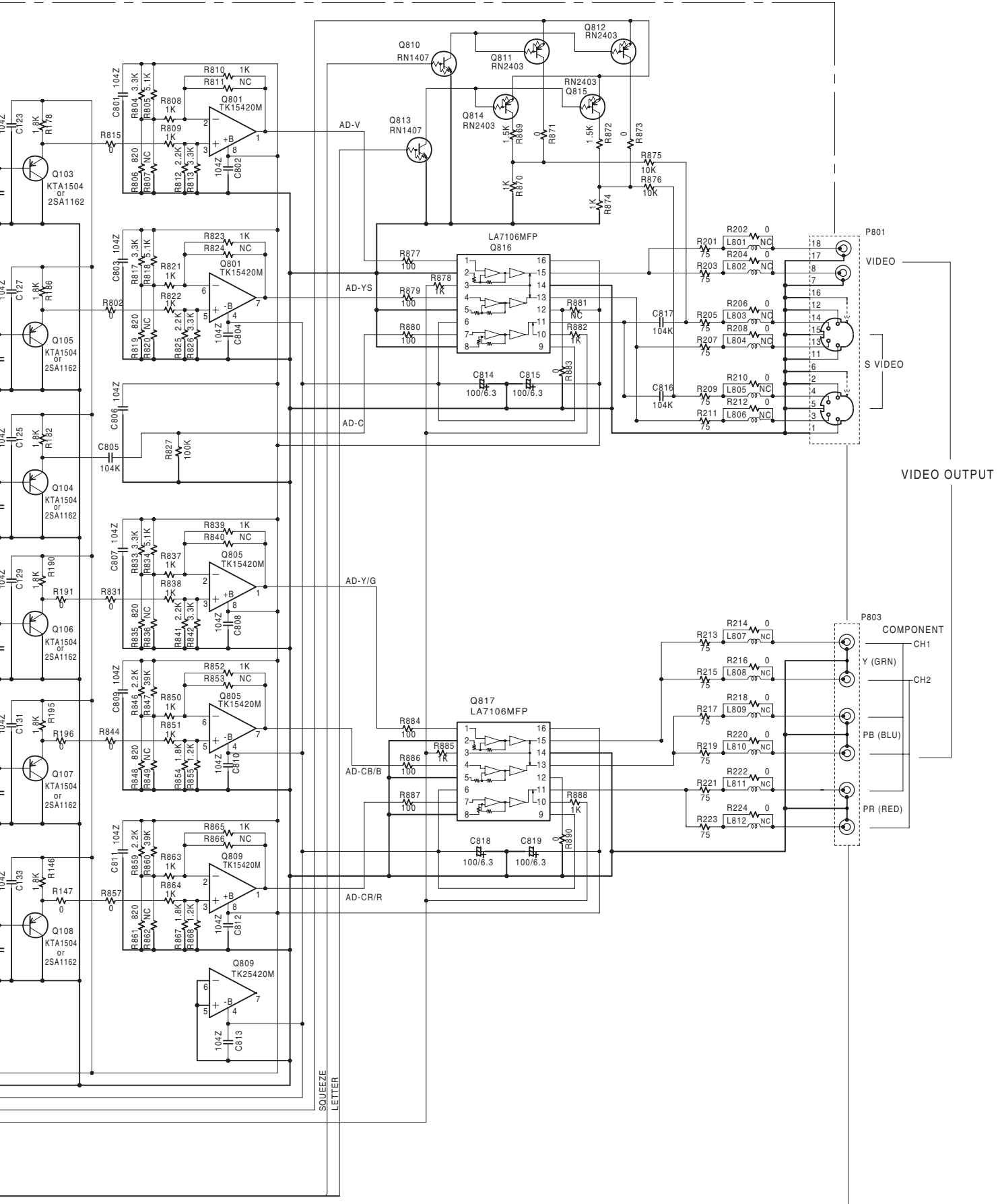



A B C D E F G H

SCHEMATIC DIAGRAMS-1

1

2

3

4

5

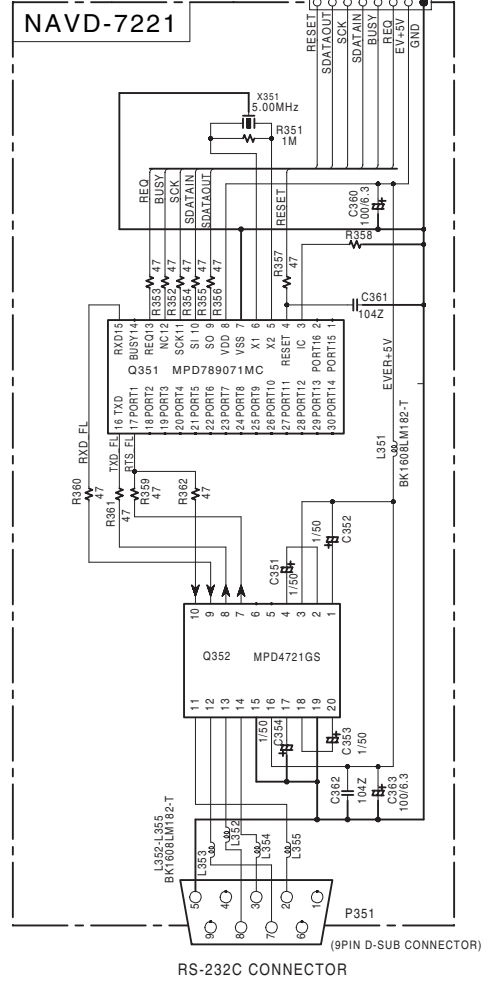
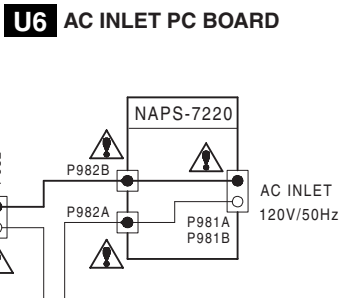
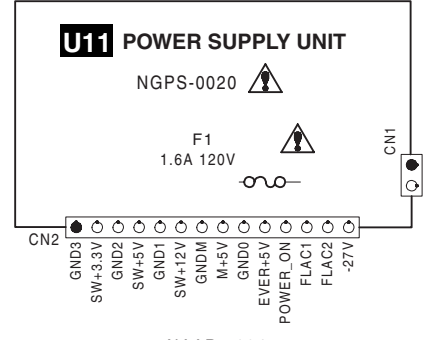
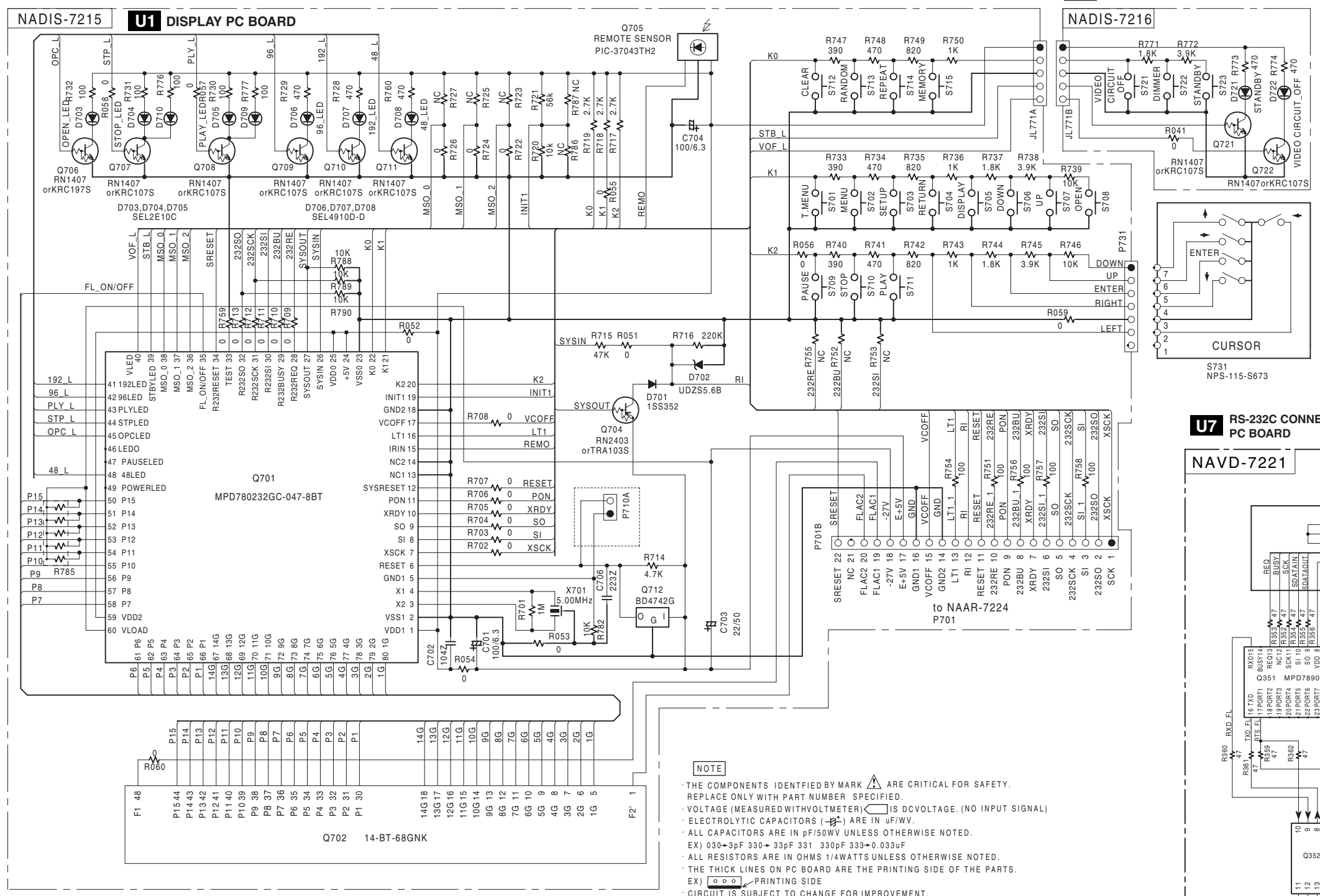

**NOTE**

- THE COMPONENTS IDENTIFIED BY MARK ARE CRITICAL FOR SAFETY. REPLACE ONLY WITH PART NUMBER SPECIFIED.
- VOLTAGE (MEASURED WITH VOLT METER) IS DC VOLTAGE. (NO INPUT SIGNAL)
- ELECTROLYTIC CAPACITORS ARE IN uF/WV.
- ALL CAPACITORS ARE IN pF/50WV UNLESS OTHERWISE NOTED.
- EX) 030-3pF 330-33pF 331 330pF 333-0.033uF
- ALL RESISTORS ARE IN OHMS 1/4WATTS UNLESS OTHERWISE NOTED.
- THE THICK LINES ON PC BOARD ARE THE PRINTING SIDE OF THE PARTS.
- EX) PRINTING SIDE
- CIRCUIT IS SUBJECT TO CHANGE FOR IMPROVEMENT.

THIS SYMBOL LOCATED NEAR THE FUSE INDICATES THAT THE FUSE USED IS SLOW OPERATING TYPE FOR CONTINUED PROTECTION AGAINST FIRE HAZARD. REPLACE WITH SAME TYPE FUSE. FOR FUSE RATING REFER TO THE MARKING ADJACENT TO THE SYMBOL.

CE SYMBOLE INDIQUE QUE LE FUSIBLE UTILISE EST LENT. POUR UNE PROTECTION PERMANENTE, N'UTILISER QUE DES FUSIBLES DE MEME TYPE. CE DERNIER EST INDIQUE LA QU LE PRESENT SYMBOLE EST APOSE.

**CAUTION**  
FOR CONTINUED PROTECTION AGAINST FIRE HAZARD, REPLACE ONLY WITH FUSE OF SAME TYPE AND RATING INDICATED.

**ATTENTION**  
AFIN D'ASSURER UNE PROTECTION PERMANENTE CONTRE LES RISQUES D'INCENDIE, REMPLACER UNIQUEMENT PAR UN FUSIBLE DE MEME TYPE ET CALIBRATION COMME INDIQUE.



SCHEMATIC DIAGRAMS-3

1

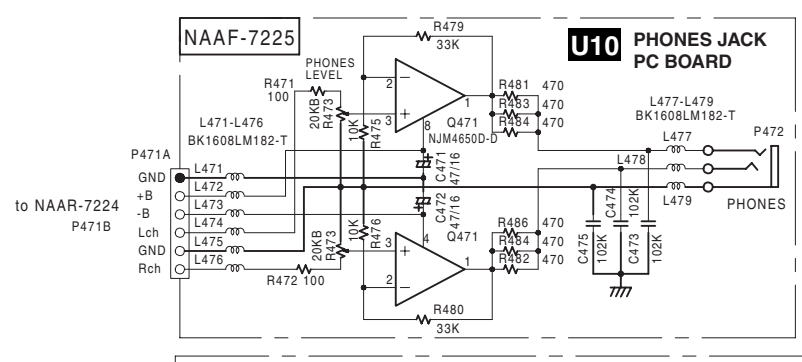

**U9 OUTPUT TERMINAL PC BOARD**  
**NAAR-7224 (2/2)**

2

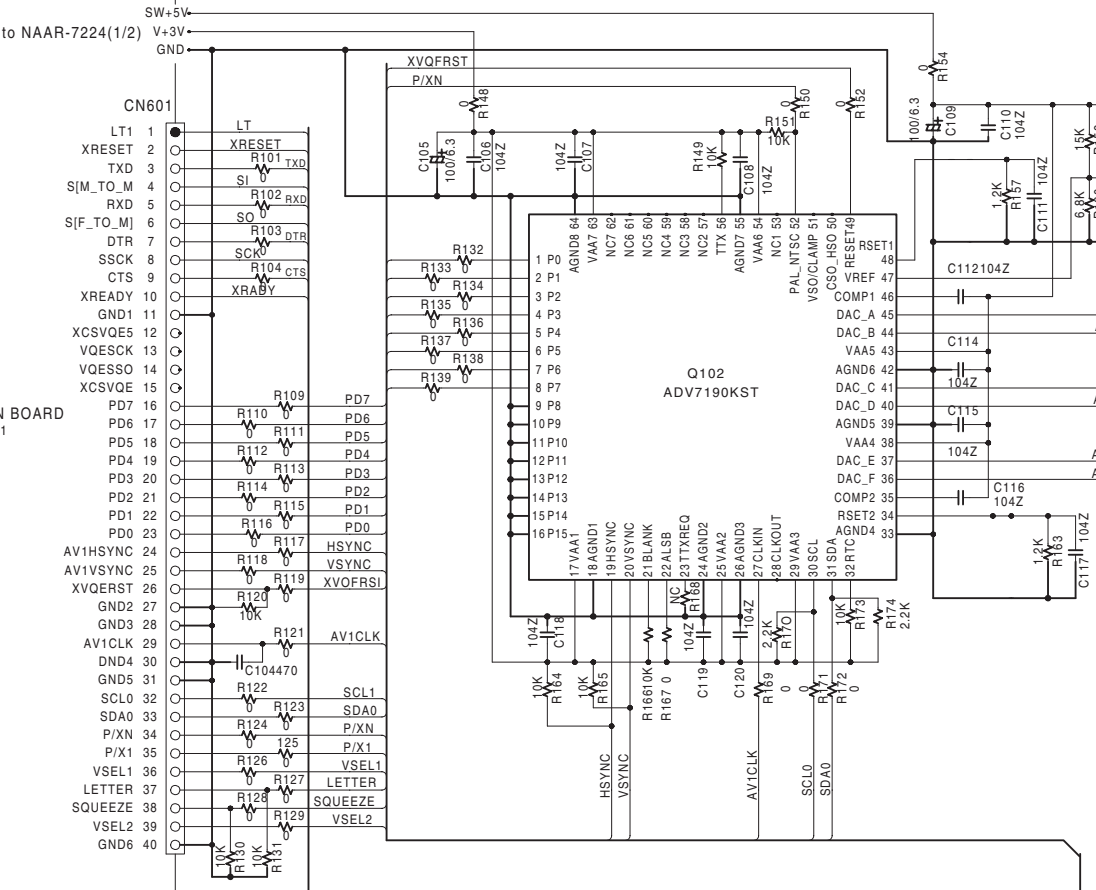

3

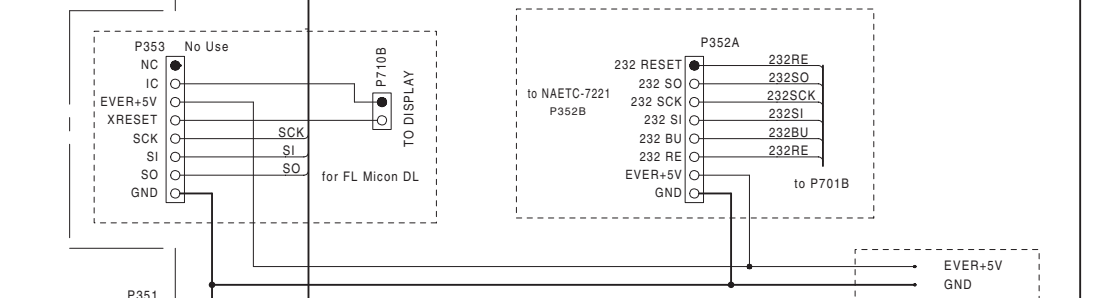

4

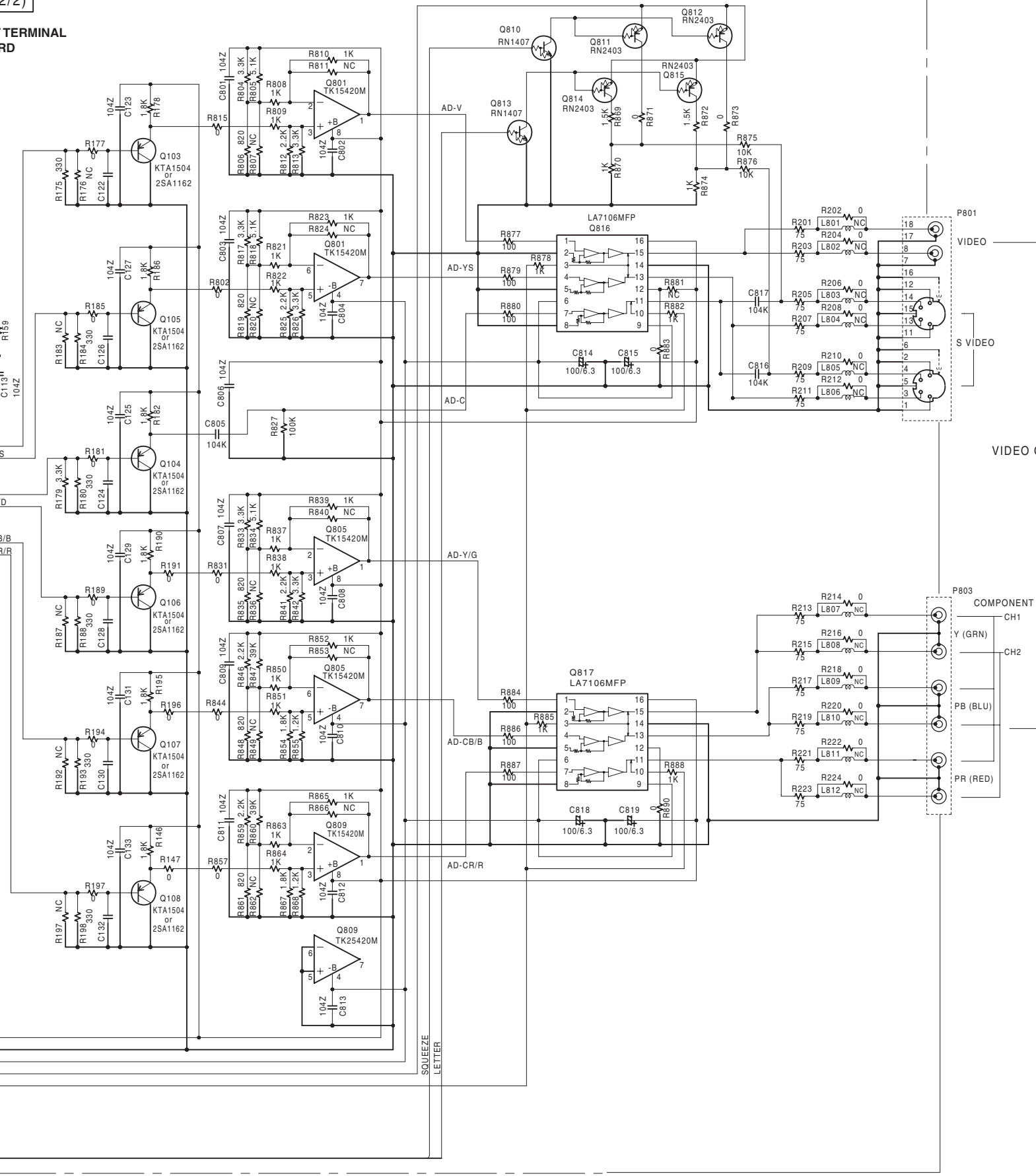

# PC BOARD CONNECTION DIAGRAM

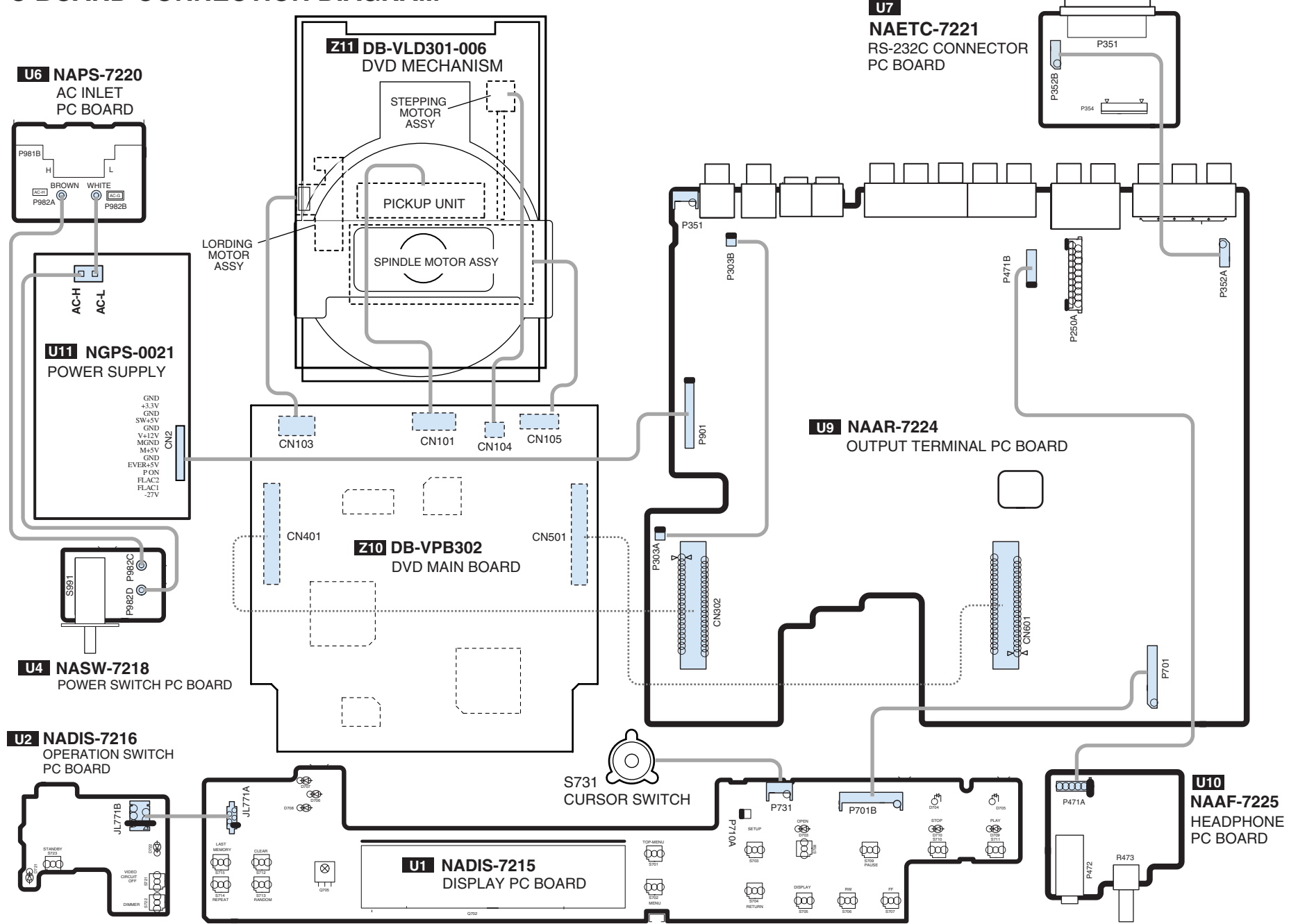



## PRINTED CIRCUIT BOARD PARTS LIST-1

**U1** DISPLAY PC BOARD(NADIS-7215-1-1G)

CIRCUIT NO.	PART NO.	DESCRIPTION
	<b>FL tube</b>	
Q702	212219	14-BT-68GNK
	<b>Remote sensor</b>	
Q705	241336	PIC-37043TH2
	<b>ICs</b>	
Q701	22241734R3	MPD780232GC-047-8BT
Q712	22241713R2	BD4742G
	<b>Transistors</b>	
Q704	2216230R2 or 2214540R2	KRA103S or RN2403
Q706, Q711	2216340R2 or 2216260R2	KRC107S or RN1407
	<b>Diodes</b>	
D701	223234R2 or 223269R2	1SS352 or 1SS355
D702	224550560R2	UDZS5.6B
D703	225374	SEL2E10C, LED
D706-D708	225291D	SEL4910D-D, LED
D709, D710	225374	SEL2E10C, LED
	<b>Ceramic resonator</b>	
X701	3010242	CST5.00MGW
	<b>Capacitors</b>	
C701,C704	355721019	CE04W6.3V-100uF, Elect.
C703	355782209	CE04W50V-22uF, Elect.
	<b>Push switches</b>	
S701-S715	25035699	NPS-111-S662
	<b>Sockets</b>	
JL771A	25051089	NSCT-5P876, Wire holder
P701B	25052359 or 25051904 or 25052543	NSCT-22P2256 or NSCT-22P1691 or NSCT-22P2440
P731	25052344 or 25051889 or 25052528	NSCT-7P2241 or NSCT-7P1676 or NSCT-7P2425
	<b>FL holder</b>	
Q702B	27191141	holder

**U2** CONTROL SWITC PC BOARD(NADIS-7216-1G)

CIRCUIT NO.	PART NO.	DESCRIPTION
	<b>Transistors</b>	
Q721,Q722	2216340R2 or 2216260R2	KRC107S or RN1407
	<b>LEDs</b>	
D721	225290	SEL4110R
D722	225291D	SEL4910D-D
	<b>Push switches</b>	
S721-S723	25035699	NPS-111-S662
	<b>Plug</b>	
JL771B	25055626	NPLG-5P588, Wire trap

**U4** POWER SWITCH PC BOARD(NASW-7218-1G)

CIRCUIT NO.	PART NO.	DESCRIPTION
	<b>Capacitor</b>	
C991	3500196S	△ RE275V-103M, IS capacitor
	<b>Push switch</b>	
S991	25035703 or 25035550	△ NPS-111-L666P or △ NPS-111-L512P, Power
	<b>Socket</b>	
P982B	2009990661UL	△ NSAS-2P0921, Socket AS

**U6** AC INLET PC BOARD(NAPS-7220-1G)

P981B	25055960	△ NPLG-2P913, AC inlet
-------	----------	------------------------

**U7** RS-232C CONNECTOR PC BOARD (NAETC-7221-1G)

CIRCUIT NO.	PART NO.	DESCRIPTION
	<b>ICs</b>	
Q351	22241624R2	MPD789071MC-011-5A4
Q352	22241537R2	MPD4721GS
	<b>Coils</b>	
L351-L355	230958R1	BK1608LM182-T, EMI filter
	<b>Ceramic resonator</b>	
X351	3010242	CST5.00MGW
	<b>Capacitors</b>	
C351-C354	354780109	CE04W50V-1uF, Elect.
C360,C363	354721019	CE04W6.3V-100uF, Elect.
	<b>Sockets</b>	
P351	25052379	NSCT-9P2277, D-sub connector
P352B	25052308 or 25052502	NSCT-8P2205 or NSCT-8P2399

**NOTE** : THE COMPONENTS IDENTIFIED BY MARK  
△ ARE CRITICAL FOR RISK OF FIRE AND  
ELECTRIC SHOCK. REPLACE ONLY WITH  
PART NUMBER SPECIFIED.

## PRINTED CIRCUIT BOARD PARTS LIST-2

**U9** OUTPUT TERMINAL PC BOARD(NAAR-7224-1D)

CIRCUIT NO.	PART NO.	DESCRIPTION	CIRCUIT NO.	PART NO.	DESCRIPTION
	<b>Photo couplers</b>		Q609,Q610	2214373R2 or	2SA1162-O or
U301,U302	24120085	GP1FA551TZ, Digital output		2214374R2 or	2SA1162-Y or
	<b>ICs</b>			2216185R2	KTA1504-GR
Q001	22241754R2	TC7WH74FU-TRB	Q611,Q612	2216141R2	HN1C03F-B
Q002,Q003	22241752R2	TC7SH32FU-TCB	Q810,Q813	2216340R2 or	KRC107S or
Q004	22241753R2	TC7SH86FU-TCB		2216260R2	RN1407
Q102	22241636R3	DB-VCP303(ADV7190KST)	Q811,Q812	2216230R2 or	KRA103S or
Q302	22274004HR2TO	TC74VHCU04FT		2214540R2	RN2403
Q303,Q304	22241638R2	TC7SHU04FU	Q814,Q815	2216230R2 or	KRA103S or
Q401,Q501,Q601	22241635R2	CS4392-KS		2214540R2	RN2403
Q403,Q404	22241383R2	NJM4565M-D	Q905	2212644	2SA1358-Y
Q503,Q504	22241383R2	NJM4565M-D		<b>Diodes</b>	
Q603,Q604	22241383R2	NJM4565M-D	D901	22380260 or	RL1N4003 or
Q801,Q805,Q809	22241443R2	TK15420M		22380032 or	1SR139-100 or
Q816,Q817	22241465R2	LA7106MFP		22380035	GP104003E
Q901	22241515R2	PQ025EZ5MZP	D902	22380293	EG01Z
Q903	222780055	78M05HF		<b>Coils</b>	
Q904	22241637R2	NJM2374A	L302,L303,L304	230958R1	BK1608LM182-T, EMI filter
	<b>Transistors</b>		L477,L478,L479	230958R1	BK1608LM182-T, EMI filter
Q103,Q108	2216185R2 or	KTA1504-GR or	L901	231253K471	NCH-1510, Choke coil
	2214373R2 or	2SA1162-O or			
	2214374R2	2SA1162-Y			
Q405-Q408	2216260R2 or	RN1407 or			
	2216340R2	KRC107S			
Q409,Q410	2214373R2 or	2SA1162-O or			
	2214374R2 or	2SA1162-Y or			
	2216185R2	KTA1504-GR			
Q411,Q412	2216141R2	HN1C03F-B			
Q505-Q508	2216340R2 or	KRC107S or			
	2216260R2	RN1407			
Q509,Q510	2214373R2 or	2SA1162-O or			
	2214374R2 or	2SA1162-Y or			
	2216185R2	KTA1504-GR			
Q511,Q512	2216141R2	HN1C03F-B			
Q605-Q608	2216340R2 or	KRC107S or			
	2216260R2	RN1407			

## PRINTED CIRCUIT BOARD PARTS LIST-3

CIRCUIT NO.	PART NO.	DESCRIPTION	CIRCUIT NO.	PART NO.	DESCRIPTION
	<b>Capacitors</b>			<b>Jacks</b>	
C105,C109	354721019	CE04W6.3V-100uF, Elect.	P301	25045589	NPJ-2PDB400, RI
C306,C309,C410	354721019	CE04W6.3V-100uF, Elect.	P302	25045592	NPJ-1PDOR403, Coaxial
C412,C512,C612	354722219	CE04W6.3V-220uF, Elect.	P401	25045671	NPJ-4PDRW469
C414,C416	354780109	CE04W50V-1uF, Elect.	P402	25045608	NPJ-6PDBRW415
C427,C428	354721019	CE04W6.3V-100uF, Elect.	P801	25045660	NPJ-10PDBY459, S video
C429,C430	374721014	ECQ-B50V-101J, Plastic	P803	25045670	NPJ-6PDGLR468, Component video
C431,C432	374722224	ECQ-B50V-222J, Plastic		<b>Sockets</b>	
C435,C436	354721019	CE04W6.3V-100uF, Elect.	CN302,CN601	25052612	NSCT-40P2509
C437,C438	354782209	CE04W50V-22uF, Elect.	P303A	200BB190415UL	NSAS-4P0816, Socket AS
C510,C527,C528	354721019	CE04W6.3V-100uF, Elect.	P351	25052344	NSCT-7P2241
C514,C516	354780109	CE04W50V-1uF, Elect.	P352A	25052308 or	NSCT-8P2205 or
C529,C530	374722224	ECQ-B50V-222J, Plastic		25052502	NSCT-8P2399
C531,C532	374724724	ECQ-B50V-472J, Plastic	P701	25052322	NSCT-22P2219
C535,C536	354721019	CE04W6.3V-100uF, Elect.	P901	2002A392815	NSAS-28P0742, Socket AS
C537,C538	354782209	CE04W50V-22uF, Elect.		<b>Radiator</b>	
C610,C627,C628	354721019	CE04W6.3V-100uF, Elect.	Q903a	27160145	RAD-51
C614,C616	354780109	CE04W50V-1uF, Elect.		<b>Screw</b>	
C629,C630	374722224	ECQ-B50V-222J, Plastic	Q903b	838430107	3TTB+10S(BC)
C631,C632	374724724	ECQ-B50V-472J, Plastic		<b>U10 PHONES JACK PC BOARD(NAETC-7225-1D)</b>	
C635,C636	354721019	CE04W6.3V-100uF, Elect.		<b>IC</b>	
C637,C638	354782209	CE04W50V-22uF, Elect.	Q471	22240581R2 or	NJM4565M or
C814,C815	354721019	CE04W6.3V-100uF, Elect.		22241383R2	NJM4565M-D
C818,C819,C915	354721019	CE04W6.3V-100uF, Elect.		<b>Coils</b>	
C905,C907	354741019	CE04W16V-100uF, Elect.	L471-L476	230958R1	BK1608LM182-T, EMI filter
C908,C910,C923	354742219	CE04W16V-220uF, Elect.		<b>Capacitors</b>	
C912	354741029S	CE04W16V-1000uF, Elect.	C471,C472	354744709	CE04W16V-47uF, Elect.
C913	354744719	CE04W16V-470uF, Elect.		<b>Resistor</b>	
C917,C919,C921	354722219	CE04W6.3V-220uF, Elect.	R473	5112463	N09RGL20KB20M, Phones level
	<b>Resistors</b>			<b>Jack</b>	
R903	453534794	RNU1/2WCJ-R47	P472	25045255	YKB26-5009, Phones
R910	453530824	RNU1/2WCJ-8R2		<b>Socket</b>	
			P471A	2009990698UL	NSAS-12P0973, Socket AS

# MICROPROCESSOR CONNECTION DIAGRAM

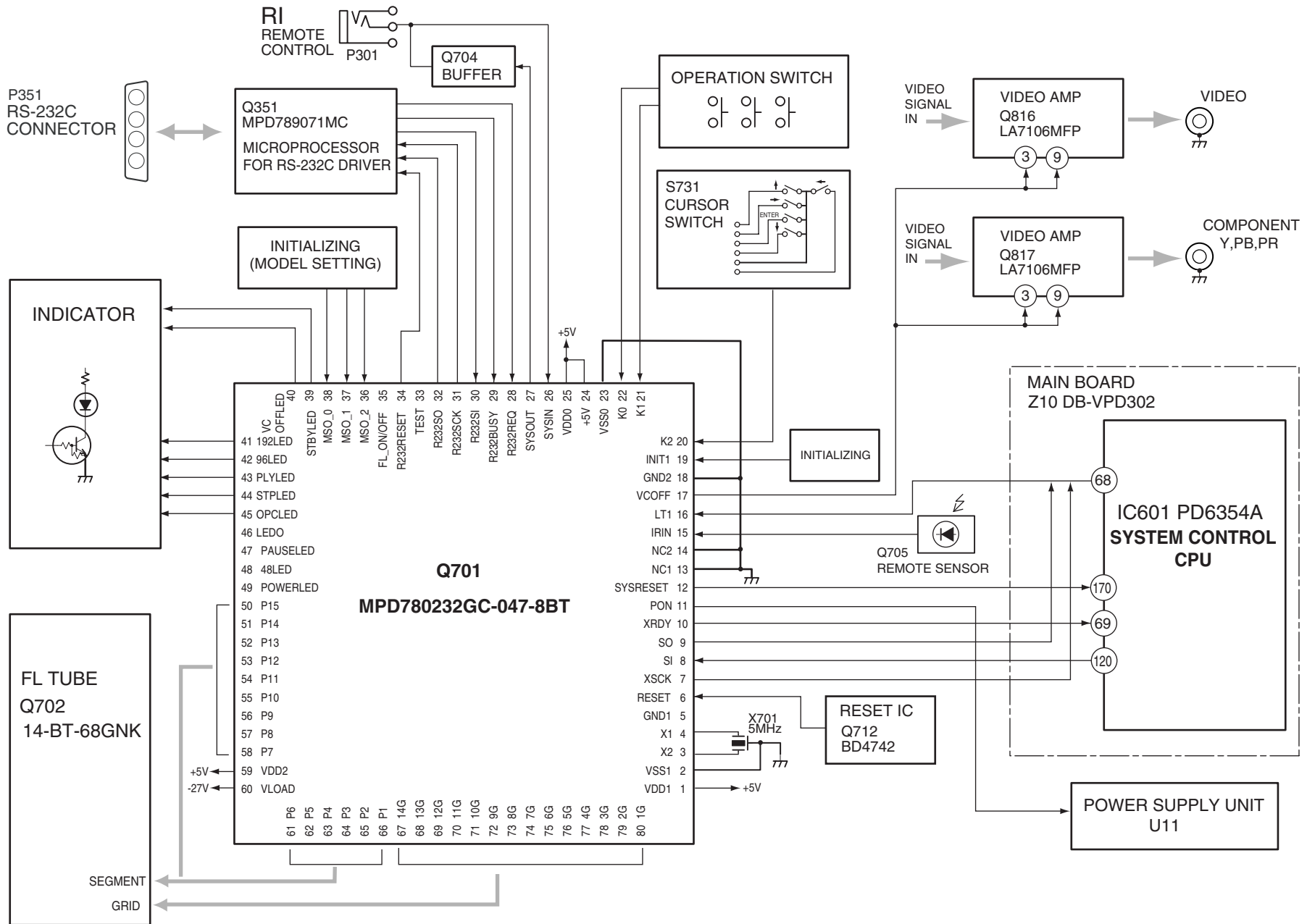



## MICROPROCESSOR TERMINAL DESCRIPTION

### Q701: MPD78022GC-047-8BT

PIN NO.	FUNCTION	I/O	DESCRIPTION	PIN NO.	FUNCTION	I/O	DESCRIPTION
1	Vdd1	—	Power supply, +5V	41	SMP192LED	O	Output pin of sampling rate 192 LED. control.
2	Vss1	—	Ground pin	42	SMP96LED	O	Output pin of sampling rate 96 LED control.
3	X2	—	Main clock input pin (5MHz)	43	PLYLED	O	Output pin of Play LED control.
4	X1	—	Main clock input pin (5MHz)	44	STPLED	O	Output pin of Stop LED control.
5	GND	—	Ground pin	45	OPCLLED	O	Output pin of Open/ close LED control.
6	RESET	—	Reset pin of microprocessor	46	—	—	Not used
7	$\overline{\text{XSCK}}$	O	Output pin of the clock for the communication with the system microcomputer, and the writing the data to flash ROM	47	—	—	Not used
8	SI	I	Input pin of the data for the communication with the system microcomputer, and the writing the data to flash ROM	48	—	—	Not used
9	SO	O	Output pin of the data for the communication with the system microcomputer, and the writing the data to flash ROM	49	—	—	Not used
10	$\overline{\text{XRDY}}$	O	Output pin of the XRDY signal for the communication with the system microcomputer.	50	P15	O	Output pin for FL segment (P15) control.
11	PON	O	Output pin of Power ON control signal for system microcomputer.	51	P14	O	Output pin for FL segment (P14) control.
12	$\overline{\text{SYSRESET}}$	O	Output pin of reset signal for system microcomputer.	52	P13	O	Output pin for FL segment (P13) control.
13	—	I	Not used	53	P12	O	Output pin for FL segment (P12) control.
14	—	I	Not used	54	P11	O	Output pin for FL segment (P11) control.
15	$\overline{\text{IRIN}}$	I	Input pin of remote control signal from remote sensor.	55	P10	O	Output pin for FL segment (P10) control.
16	LT1	I	Input pin of LT data for communication with the system microcomputer.	56	P9	O	Output pin for FL segment (P9) control.
17	VCOFF	O	Output pin of video circuit control signal.	57	P8	O	Output pin for FL segment (P8) control.
18	GND	—	Ground pin for D/A converter.	58	P7	O	Output pin for FL segment (P7) control.
19	INIT1	I	Input pin for initializing set. (Analog signal)	59	Vdd2	—	Power supply pin (+5V)
20	K2	I	Input pin for the key operation of the unit.	60	Vload	—	FIP control pin to connect pull down resistor
21	K1	I	Input pin for the key operation of the unit.	61	P6	O	Output pin for FL segment (P6) control.
22	K0	I	Input pin for the key operation of the unit.	62	P5	O	Output pin for FL segment (P5) control.
23	Vss0	—	Ground pin	63	P4	O	Output pin for FL segment (P4) control.
24	+5V	—	Power supply pin of D/A converter, +5V	64	P3	O	Output pin for FL segment (P3) control.
25	Vdd0	—	Power supply, +5V	65	P2	O	Output pin for FL segment (P2) control.
26	$\overline{\text{SYSIN}}$	I	Input pin of system control signal (RI).	66	P1	O	Output pin for FL segment (P1) control.
27	$\overline{\text{SYSOUT}}$	O	Output pin of system control signal (RI).	67	14G	O	Output pin for FL grid (G14) control.
28	R232REQ	I	Input pin of REQ signal from microprocessor for RS-232C driver.	68	13G	O	Output pin for FL grid (G13) control.
29	R232BUSY	I	Input pin of BUSY signal from microprocessor for RS-232C driver	69	12G	O	Output pin for FL grid (G12) control.
30	R232SI	I	Input pin of SI signal from microprocessor for RS-232C driver	70	11G	O	Output pin for FL grid (G11) control.
31	R232SCK	O	Input pin of SCK signal from microprocessor for RS-232C driver	71	10G	O	Output pin for FL grid (G10) control.
32	R232SO	O	Input pin of SO signal from microprocessor for RS-232C driver	72	9G	O	Output pin for FL grid (G9) control.
33	TEST	I	Input pin for test mode.	73	8G	O	Output pin for FL grid (G8) control.
34	R232RESET	O	Output pin of reset signal to microprocessor of RS-232C driver	74	7G	O	Output pin for FL grid (G7) control.
35	FLON_OFF	O	Output pin of FL filament on/off control.	75	6G	O	Output pin for FL grid (G6) control.
36	MS0_2	I	Input pin-2 for initializing. (for model select)	76	5G	O	Output pin for FL grid (G5) control.
37	MS0_1	I	Input pin-1 for initializing set. (for model select)	77	4G	O	Output pin for FL grid (G4) control.
38	MS0_0	I	Input pin-0 for initializing set. (for model select)	78	3G	O	Output pin for FL grid (G3) control.
39	STBYLED	O	Output pin of standby LED control .	79	2G	O	Output pin for FL grid (G2) control.
40	VCOFFLED	O	Output pin of video circuit off LED control.	80	1G	O	Output pin for FL grid (G1) control.

## DISASSEMBLING PROCEDURES-1

1. Optical pick-up are parts which are easy to receive damage with static electricity.  
Therefore, in case reassembly mechanism, take the measures against static electricity.
2. The number of ( ) in the explanatory note and ○ in the figure shows Ref. No. of the exploded view.

### How to remove the DVD mechanism from chassis

- 1 Remove the top cover
- 2 Begin to pull the tray by rotating the gear pulley (14) clockwise.

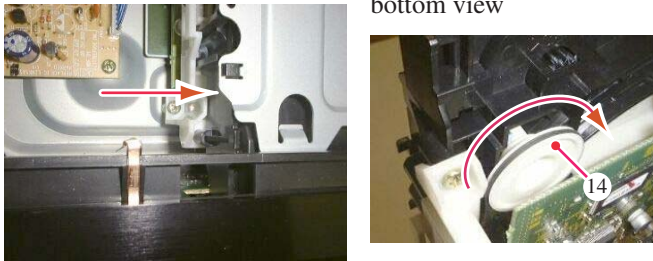

- 3 Remove the tray panel.

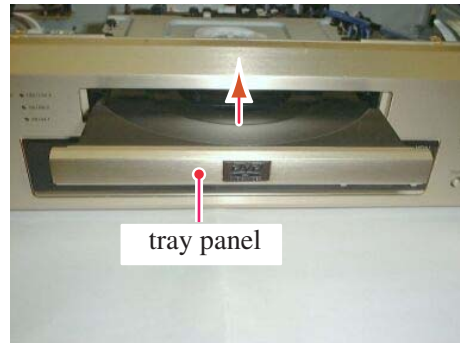

- 4 Remove the four screws which is fixing the dvd mechanism to the chassis, and remove the mechanism from chassis.

### How to disassembling the DVD mechanism

- 1 Remove the screw and remove the bridge (19).

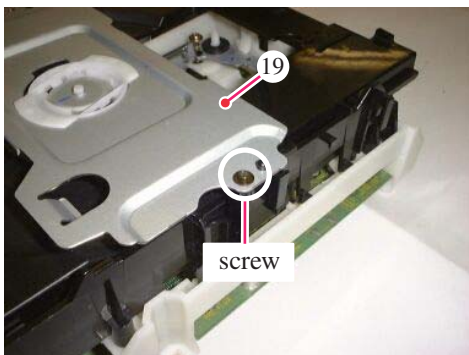

- 3 Remove the tray by pressing down the stopper SW lever (17).

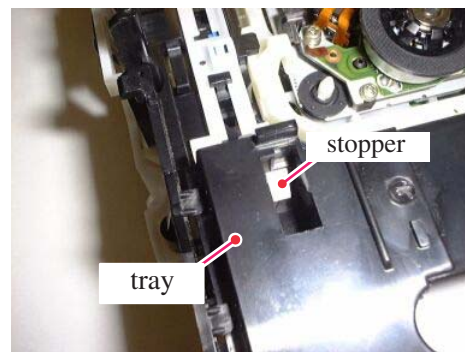

- 2 Begin to pull the tray by rotating the gear pulley (14) clockwise.

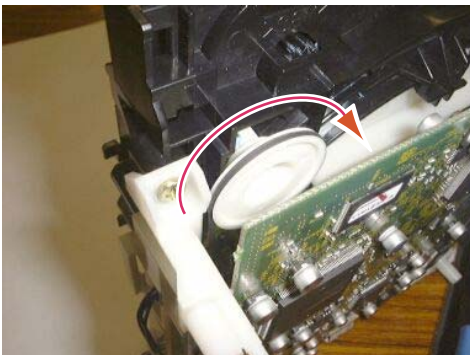

- 4 Set the pick short switch to short side.  
[NOTE]  
Do not disconnect the FFC and wire before doing this work.

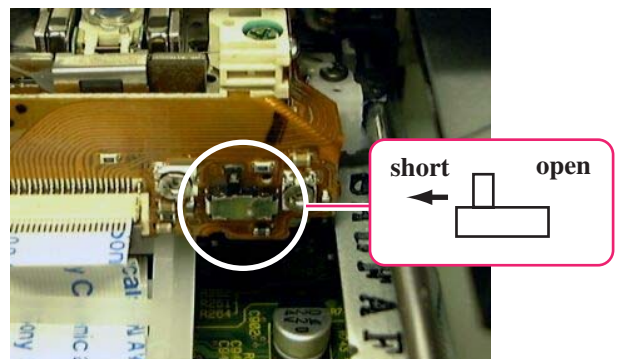

## DISASSEMBLING PROCEDURES-2

### How to disassembling the DVD mechanism

- 5** Disconnect the three FFCs and the wire from the main board.

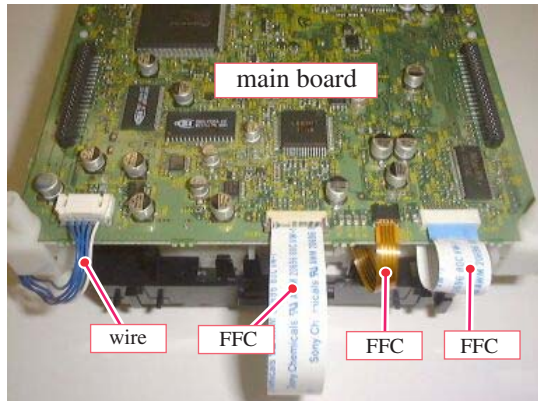

- 6** Remove the two screws which is fixing the main board to the mechanism, and remove the main board.

- 7** Remove the traverse unit by pressing down the four stoppers.

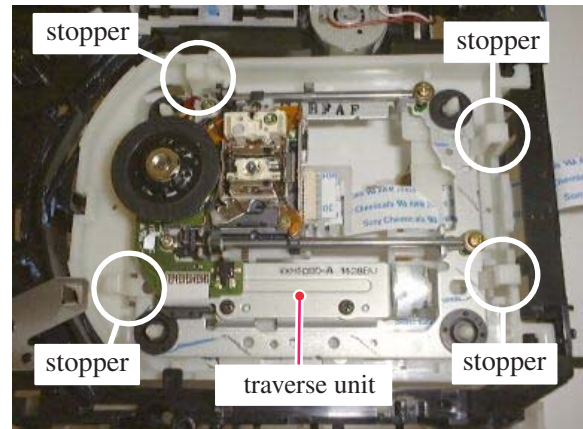

### How to reassembling the DVD mechanism

1. To reassemble each mechanism, reverse the applicable "disassemble procedures".

**7** → **6** → ... → **1**

### Notes in each process

#### 1. Attachment of tray.

Insert it after matching the triangle mark of the loading base and the position of pin on the drive cam

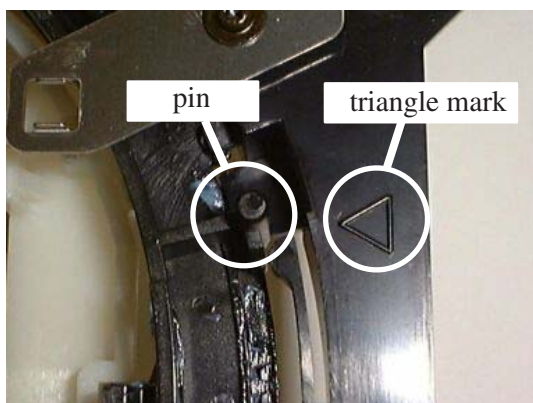

#### 2. Set the pickup short switch.

Set the pick short switch to open side.

[NOTE]

Do not set the switch to open side before doing connect the FFC and wire to main board.

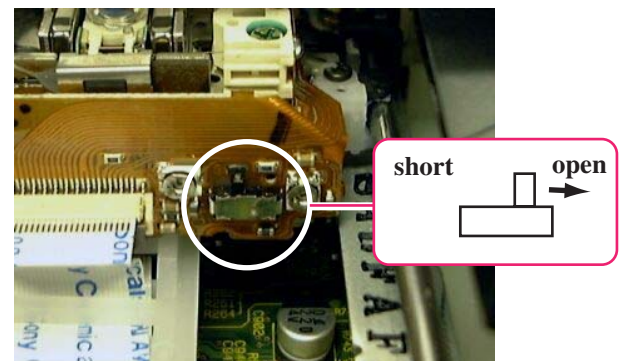

### Replacement of DVD main board

After replacement of the DVD main board (DB-VPB302) should do the following work.

#### 3. Set the ID number

The necessity of inputting ID data into the unit.

Refer to "Setting the ID number and ID data" of "UPGRADE FIRMWARE" about the method of input ID data.

#### 2. Set the region code

It is unnecessary.

Unit is power on, the region code will be set up automatically.

#### 1. Setup of the firmware

Firmware already exists in the main board.

Be sure to check the version of the firmware.

Refer to "UPGRADE FIRMWARE"



## DISASSEMBLING PROCEDURES-3

### Replacement of DVD mechanism

The display label of the ID number is stuck on the upper part of the DVD mechanism.

ID number needs to be displayed absolutely.

In case replacement DVD mechanism, do the following work absolutely.

1. Stick on the mechanism after replacement the ID label stuck on the DVD mechanism before exchange.
2. When the work which you restick cannot be performed easily, you may post and stick the ID number on the blank level (Part No.29362727).

Before replace

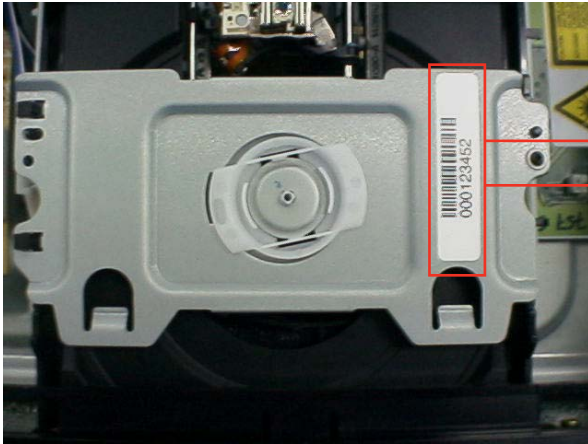

Copy the ID number  
In this case, the bar code  
is unnecessary.

XXXXXXXXXX

Restick

Stick

After replace

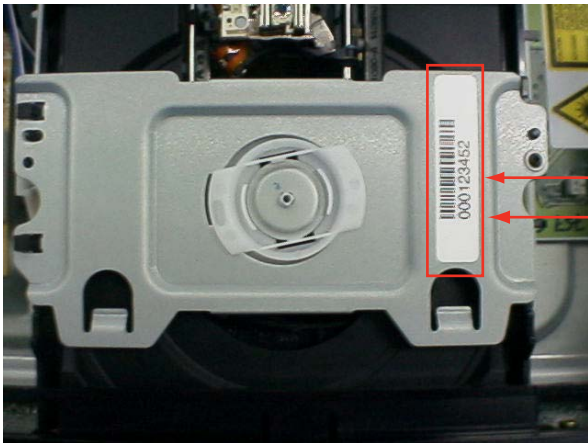

# UPGRADE FIRMWARE-1

## Prepares for upgrade firmware

**ID DATA DISC (DB-VPB302)**

**Part No. 0R117**

It is used for the input of ID data.

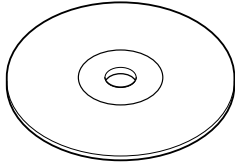

**REMOTE CONTROLLER for UPGRADE**

**Part No. 24140451S**

It is remote control of the exclusive use for inputting ID data.  
Can not the input of ID data by remote controller attached to the unit.

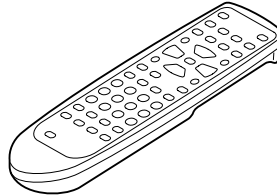

**INTERFACE JIG**

**Part No. GGF1348**

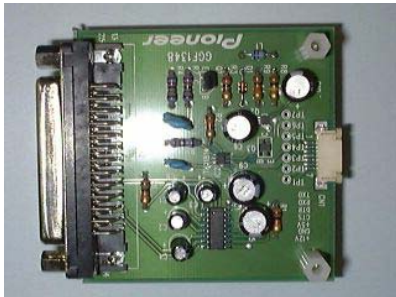

**Part No. 0J13**

OR

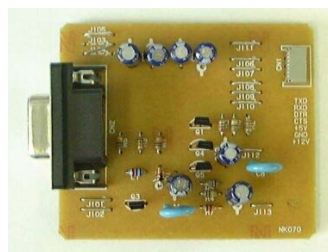

**RS-232C Cable (Straight type Cable)**

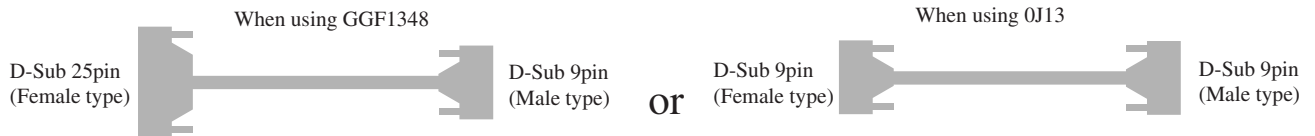

**Flexible flat cable**

**Part No.:GGD1231 or 0F001**

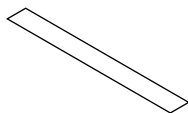

**Video cable**



**PC (Personal computer)**

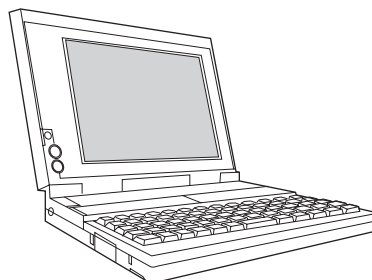

**Monitor TV**

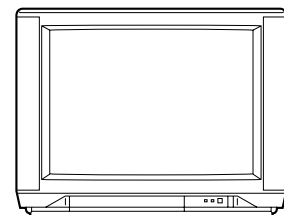

# UPGRADE FIRMWARE-2

## Connections

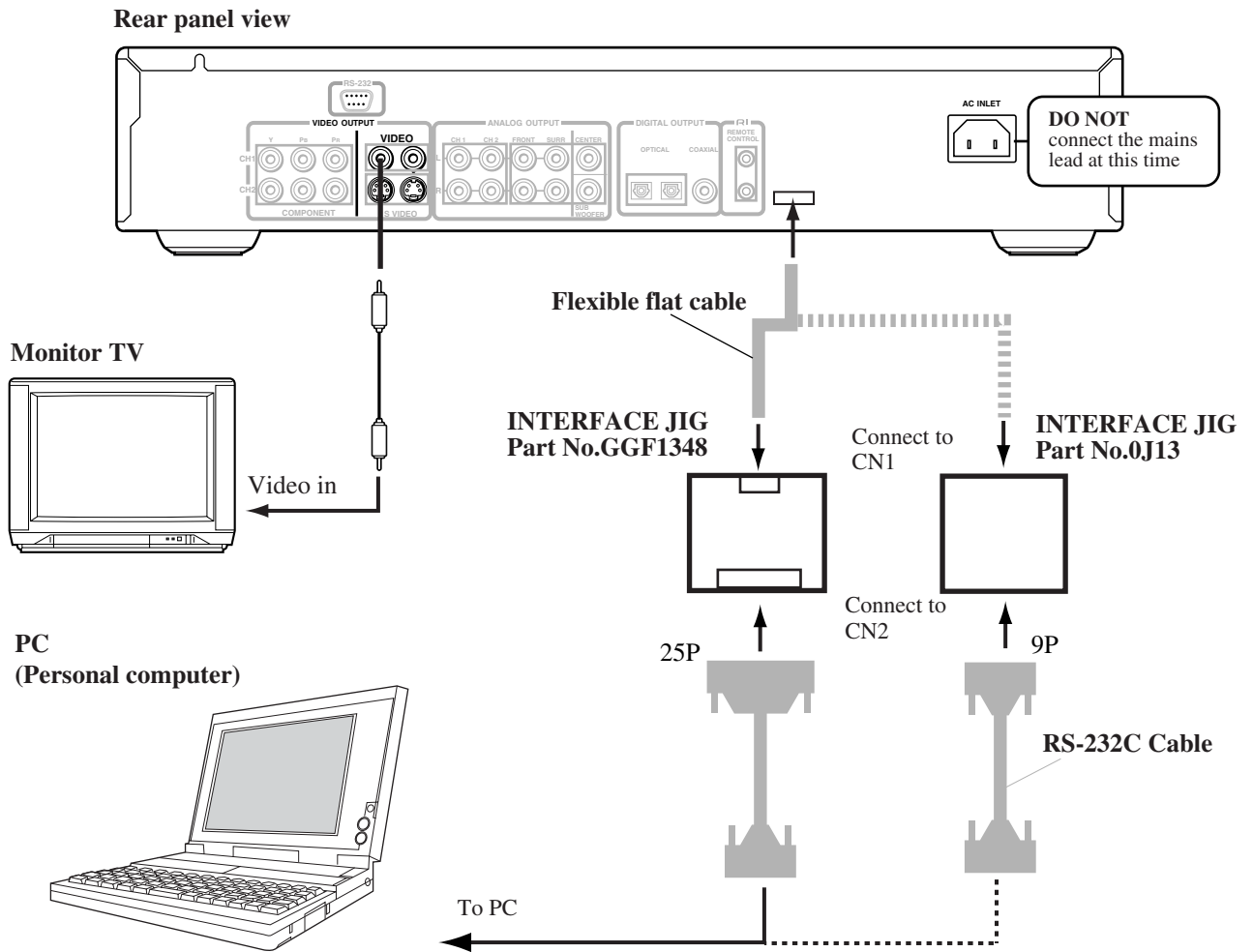

### Prepare the file required for rewriting of the firmware.

Build the folder to C drive of the hard disk of PC, and put in the file required for the folder.

**The required file**

NOTE: This is one example.

**1. ok\_down.exe**

Rewriting tools

**2. down.bat**

Rewriting tools

**3. b1ck1048.sz0**

Firmware program

The file name changes with versions of the firmware.

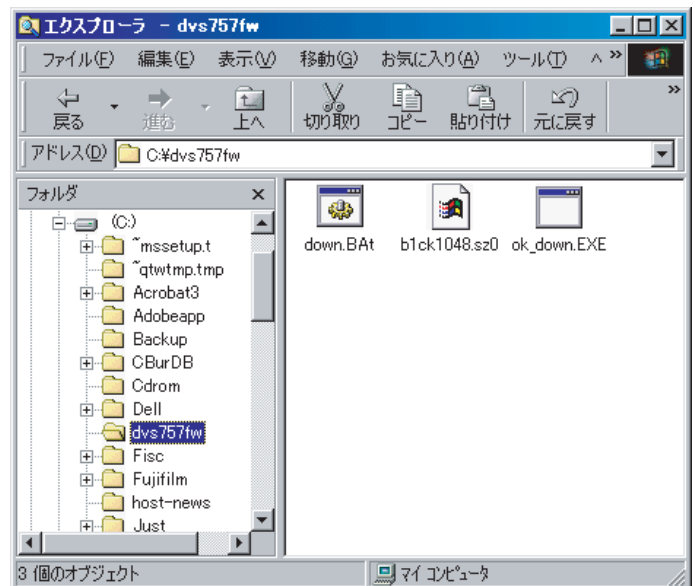

## UPGRADE FIRMWARE-3

### Pre programming the remote controller

Before using remote control for upgrade firmware, it is necessary to carry out the following operation.

1. Set the DVD/TV switch to TV



2. While holding down the **STANDBY** button on the Remote controller that you want to program, press the **ENTER** button, and then release both button.
3. 1 key is pushed, it continues within 20 seconds, and 0 key is pushed after that.
4. The complete of the setting of remote control.

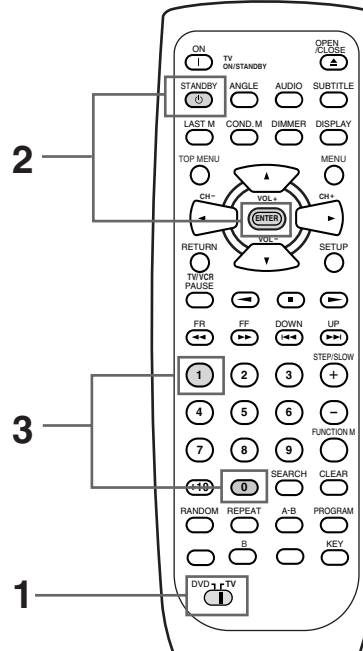

### The order of work

#### In the case of upgrade firmware

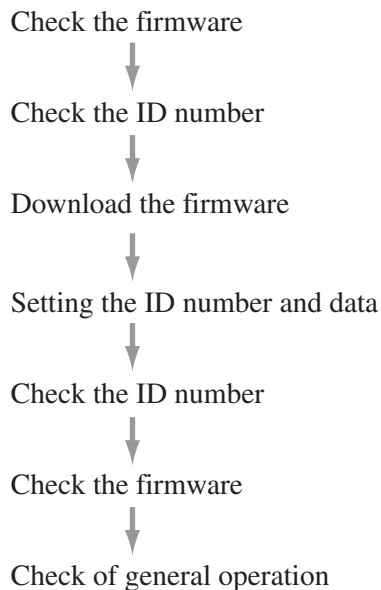

#### In the case of replace of the DVD main board

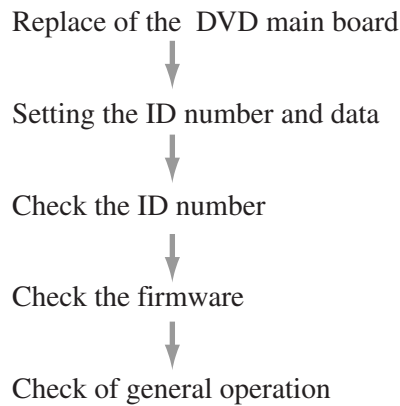

## UPGRADE FIRMWARE-4

### Check the firmware

1. Press the **SETUP** key
2. Operate the **CURSOR** switch to make up the **Setup menu mode** are selected on monitor TV.
3. Press the **DISPLAY** button  
The region and FW version information will appear on the monitor TV.

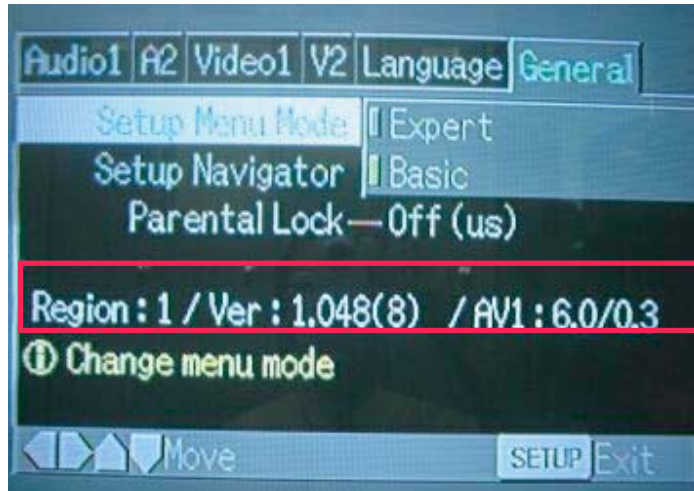

### About ID number and ID data input

It is necessary to set up an individual number (ID number and ID data) for every player in the DVD audio correspondence player.  
The guarantee of operation becomes impossible if this ID number and ID data are not set up correctly.

It is the following case that the input of ID number is required.

1. After download of the data to the flash ROM of the unit.
2. When displayed on FL display as "No ID Number" after turning ON the power supply of the unit.
3. When displayed on FL display as "No ID DATA".

### Check ID number

The input of ID number is needed by the work of rewriting of the farmware.  
Make the note by checking ID number of the set with the following procedure first.  
ID number is displayed also on the DVD mechanism upper part.  
See the display, when you cannot check ID number by the following method.

1. Check the connecting the unit to PC and monitor TV.
2. **Switch ON** the power of unit.
3. Check that the disk is not contained in the unit.
4. Press and hold down **CLEAR** button, then press the **KEY** button of remote controller.
5. Press the **VOL+** button.

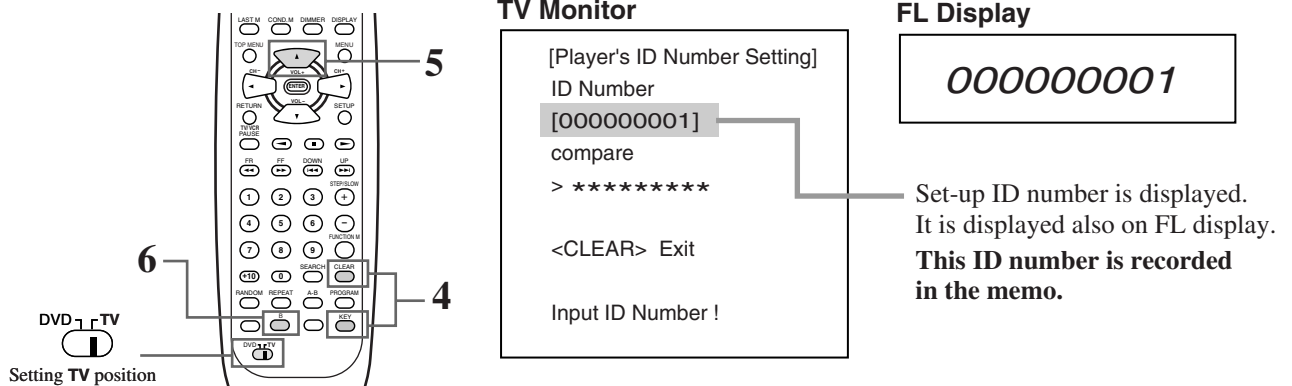

6. Press the **B** button, and check mode is ended.



## UPGRADE FIRMWARE-5

### Download procedures

#### [NOTES]

This procedure document supposing using Japanese PC.

The program file name, the folder name, etc. are examples.

1. Start MS-DOS prompt using the start-up menu of PC.

#### Windows of MS DOS prompt

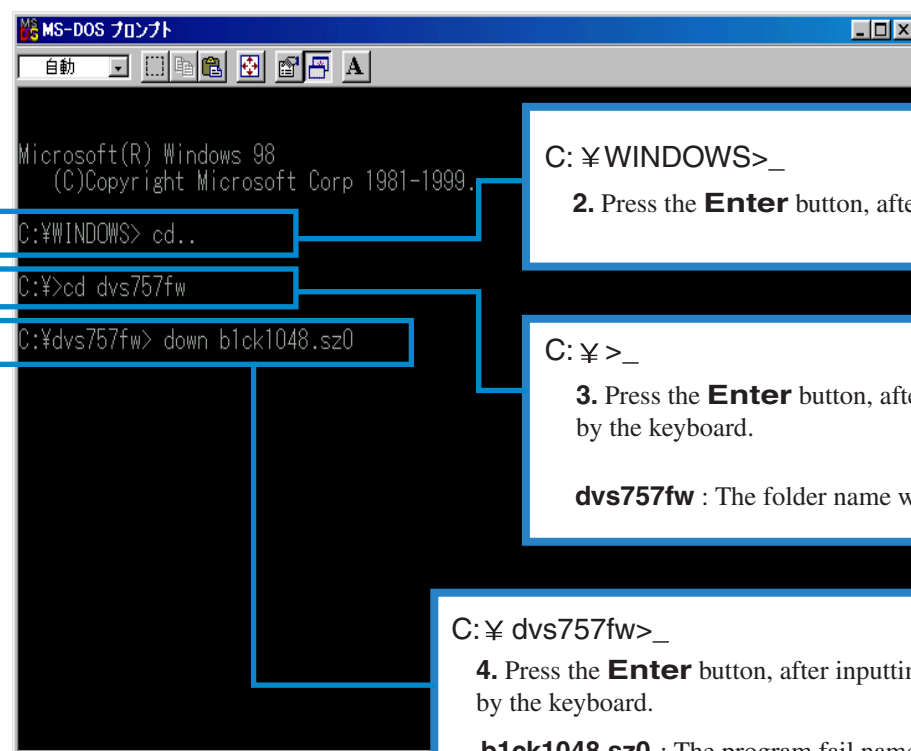
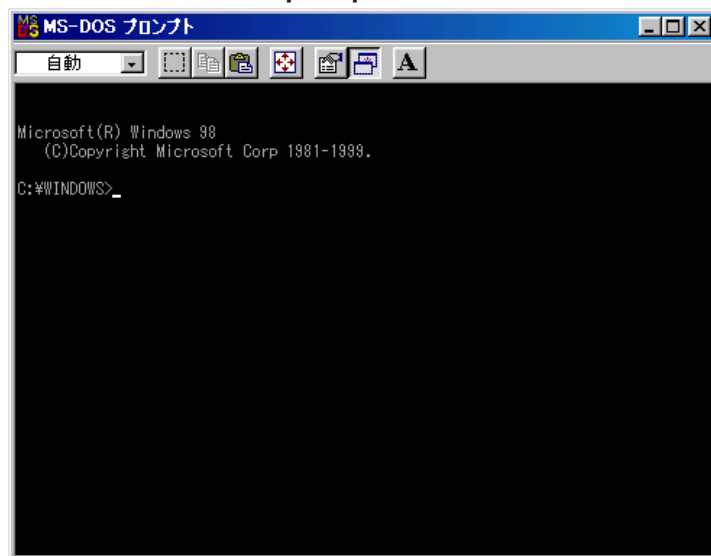

C: ¥WINDOWS>\_

2. Press the **Enter** button, after inputting **cd..** by the keyboard.

C: ¥ >\_

3. Press the **Enter** button, after inputting **cd** | **dvs757fw** by the keyboard.

Space

**dvs757fw** : The folder name which saves the program file

C: ¥ dvs757fw>\_

4. Press the **Enter** button, after inputting **down** | **b1ck1048.sz0** by the keyboard.

Space

Zero

**b1ck1048.sz0** : The program fail name

The file name changes with versions of FW.

## UPGRADE FIRMWARE-6

### Download procedures

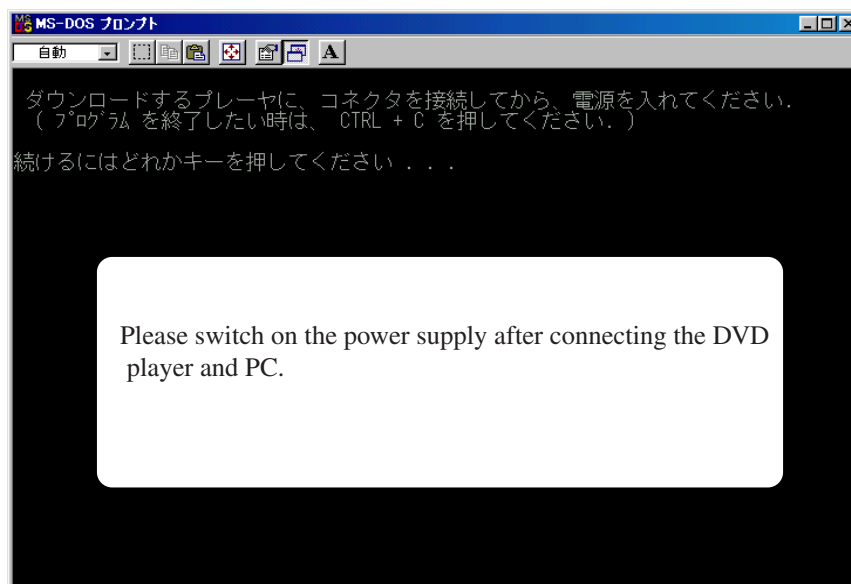

4. Check that the PC and TV monitor are correctly connected with unit.
5. Check that the disk is not contained in the disc.
6. Turn ON the power supply switch of the unit.
7. Press the **Enter** key of PC.
8. Press the **Enter** button, after inputting **MO** by the keyboard of PC.

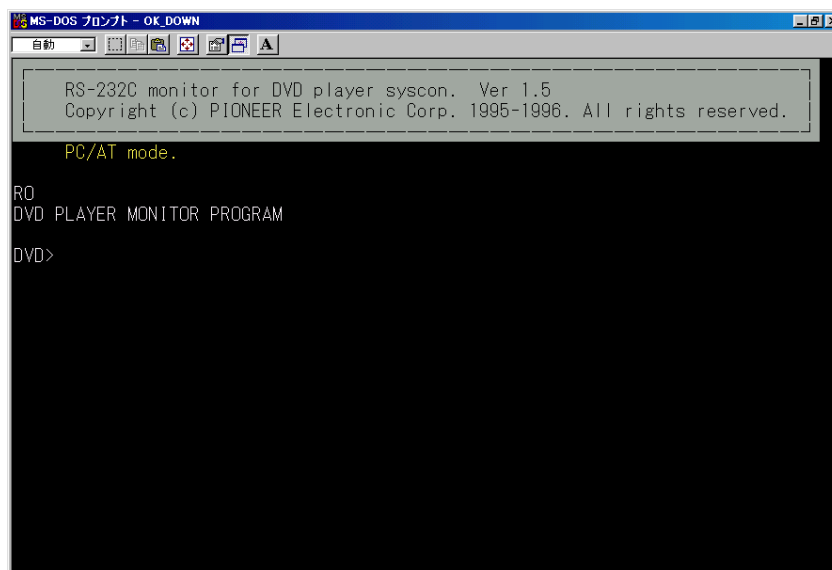

# UPGRADE FIRMWARE-7

## Download procedures

9. Press the **Enter** button, after inputting **SZL** by the keyboard of PC.

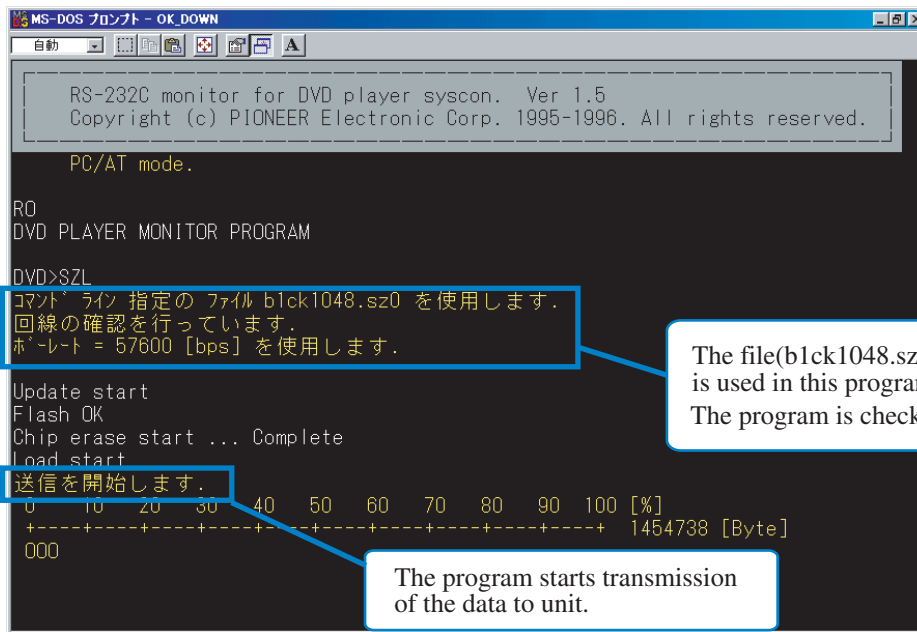

FL Display

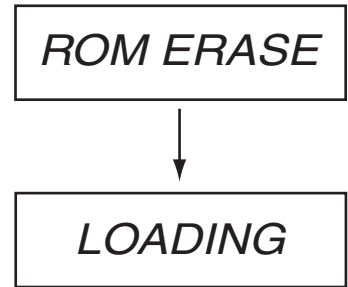

The file(b1ck1048.sz0) specified by the command line is used in this program. The program is checking the circuit.

The program starts transmission of the data to unit.

Waiting for from 5 to 10 minutes.

The state which download completed

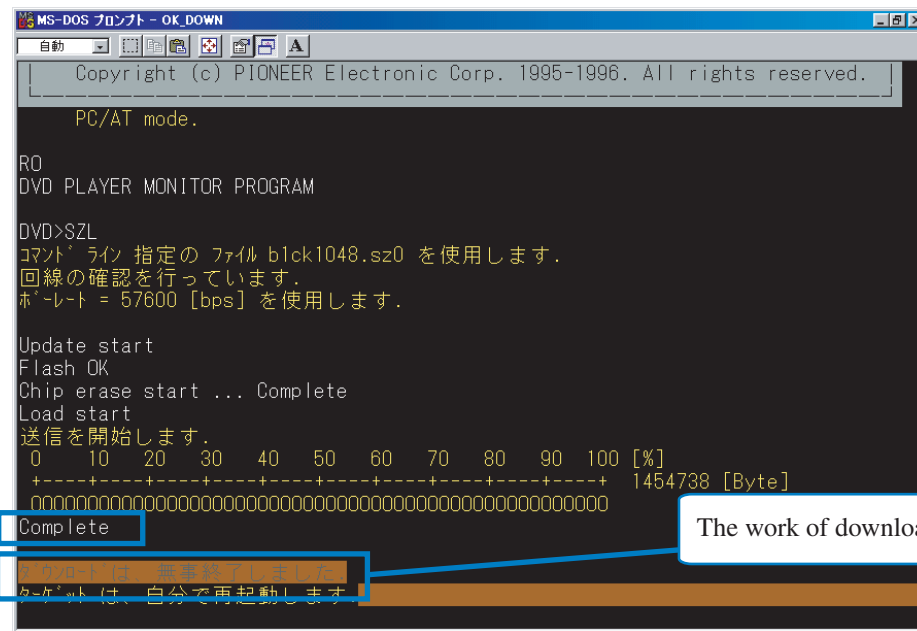

FL Display



The work of download was completed satisfactory.

ターゲットは、再起動します。

# UPGRADE FIRMWARE-8

## Setting the regional code

Not need to set up region code at DPS-7.2.  
Because the region code is set up automatically.

## Setting the ID number and ID data

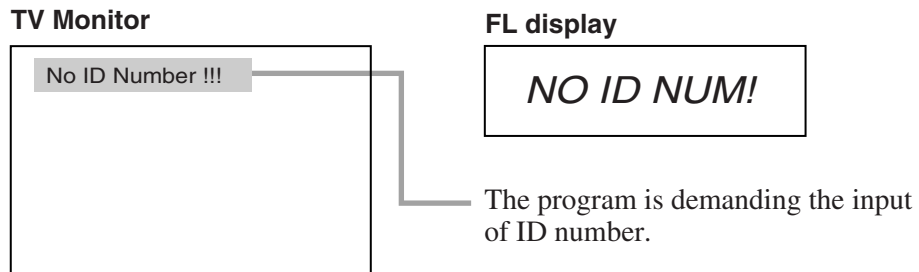

### Into the input mode of ID number.

1. Press and hold down the **CLEAR** button, then press the **KEY** button
2. Press the **VOL+** button.

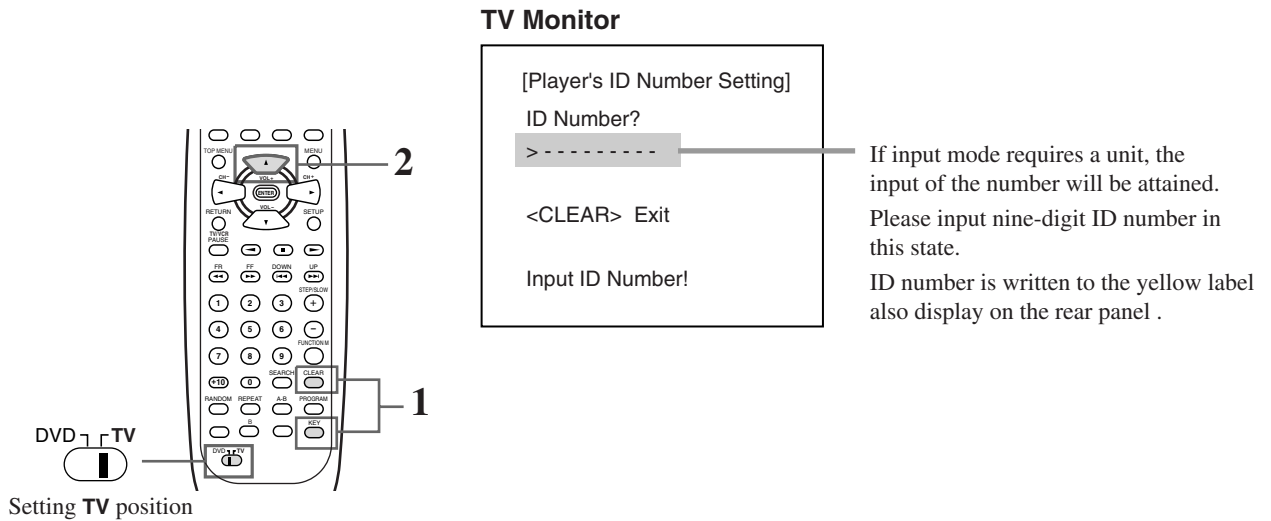

# UPGRADE FIRMWARE-9

## Setting the ID number.

1. Input the ID number recorded before using the number button. (Refer to "Check ID number")

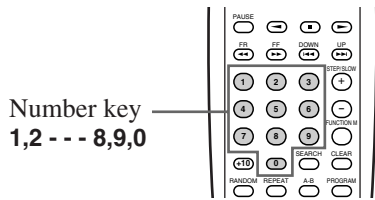

### TV Monitor

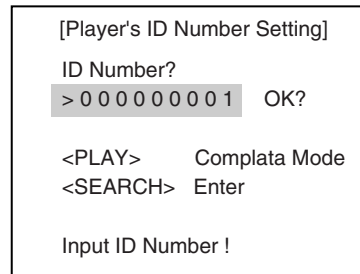

2. Press the **VOL -** button.

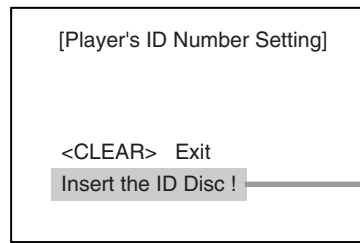
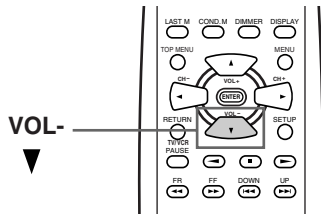

### FL display



If ID number is set up, it will be in ID data input state from CDR.

## ID data setting

1. Press the **open/close** button of set and the tray is pulled out.
2. Load the ID data disc.
3. Press the **open/close** button and tray is closed.

### TV Monitor

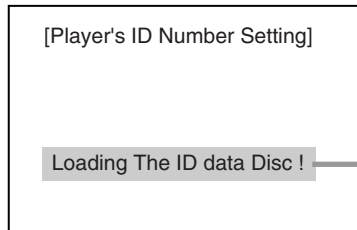

### FL display



It becomes such a display during reading of data from CDR.

The read-in work of ID data from CDR starts automatically.

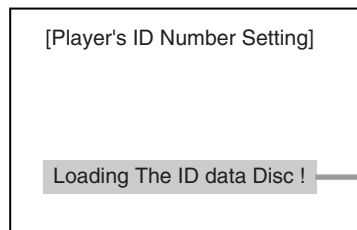

If reading completes ID data from CDR, next, the writing of ID data to the flash ROM of a set will start.

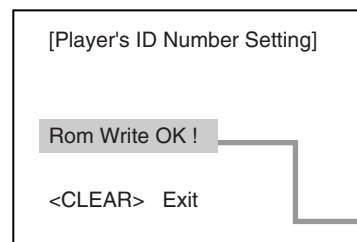
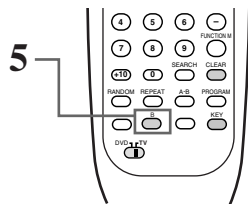

If the writing of ID data to a flash ROM is completed, it will be displayed as "Rom Write OK!"

4. Check being displayed as "Rom Write OK"
5. Press the **B** button of remote controller and setting mode is ended.
6. Put out the disc.
7. Check the ID number.
8. Check the Firmware.

# PACKING PROCEDURES

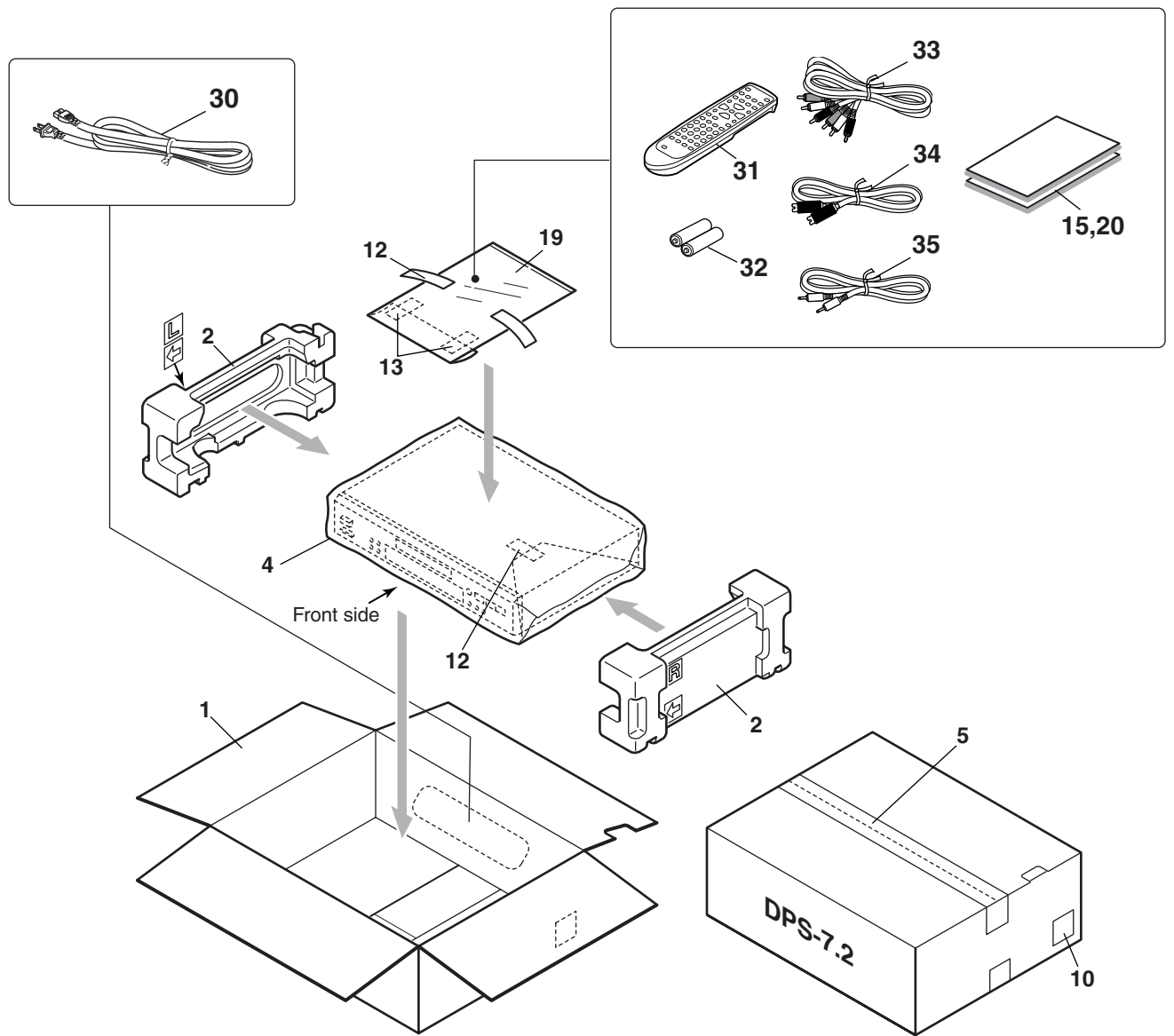

## PARTS LIST

REF.NO.	PART NO.	DESCRIPTION	REF.NO.	PART NO.	DESCRIPTION
1	29053801A	Carton box B MDD1N	20	29343135	Instruction manual, E
2	29091986	Pad AS	30	253297KAW	AS-UC-2, Power supply cord
4	29100037-1A	Poly bag (650 x 500)	31	24140451	RC-451DV, Remote controller
5	29110071 or 29110098	Tape, SOP-400(CLEAR50MT) or Tape, W50 3M NO 371	32	3010054	Battery, UM-3
10	29362933	UPC label AS	33	2010379	RCA3P(YWR), Pin cord AS
12	29110149	Tape NO.29	34	2010380	S Video cord
13	29110161	Tape	35	2010200	3.5-Mini plug (RI)
15	29365089	Warranty card (INTEGRA)			

**NOTE:** THE COMPONENTS IDENTIFIED BY MARK ARE CRITICAL FOR RISK OF FIRE AND ELECTRIC SHOCK. REPLACE ONLY WITH PART NUMBER SPECIFIED.

---

Integra Division of  
**ONKYO CORPORATION**

Sales & Product Planning Div. : 2-1, Nisshin-cho, Neyagawa-shi, OSAKA 572-8540, JAPAN  
Tel: 072-831-8111 Fax: 072-833-5222 <http://www.onkyo.co.jp/>

Integra Division of  
**ONKYO U.S.A. CORPORATION**

18 Park Way, Upper Saddle River, N.J. 07458, U.S.A.  
Tel: 201-785-2600 Fax: 201-785-2650 E-mail: [integra@onkyousa.com](mailto:integra@onkyousa.com) <http://www.integrahometheater.com>